



Smart Monitor System
MMK
Operation Manual

Federal Communication Commission Interference Statement

This equipment has been tested and found to comply with the limits for a Class B digital device, pursuant to Part 15 of the FCC Rules. These limits are designed to provide reasonable protection against harmful interference in a residential installation. This equipment generates, uses and can radiate radio frequency energy and, if not installed and used in accordance with the instructions, may cause harmful interference to radio communications. However, there is no guarantee that interference will not occur in a particular installation. If this equipment does cause harmful interference to radio or television reception, which can be determined by turning the equipment off and on, the user is encouraged to try to correct the interference by one or more of the following measures:

- Reorient or relocate the receiving antenna.
- Increase the separation between the equipment and receiver.
- Connect the equipment into an outlet on a circuit different from that to which the receiver is connected.
- Consult the dealer or an experienced radio/TV technician for help.

FCC Caution: Any changes or modifications not expressly approved by the party responsible for compliance could void the user's authority to operate this equipment.

This device complies with Part 15 of the FCC Rules. Operation is subject to the following two conditions: (1) This device may not cause harmful interference, and (2) this device must accept any interference received, including interference that may cause undesired operation.

CE Declaration of Conformity

This equipment complies with the requirements relating to electromagnetic compatibility, EN55022 class B for ITE and EN 50082-1. This meets the essential protection requirements of the European Council Directive 89/336/EEC on the approximation of the laws of the Member States relating to electromagnetic compatibility.

Environment

The device you have purchased, as well as any used batteries must not be disposed of with household waste. You should return these to your distributor if they are to be replaced or disposed of them in an approved recycling center.

Trademarks

iPad™, iPad mini™, iPhone™, iTunes™ and iOS™ are registered trademarks of Apple Inc., USA. Android is a trademark of Google Inc., or others are registered trademarks of their respective owners.

WARNING!

1. Read these installation instructions carefully before connecting the device to its power.
2. To reduce the risk of electric shock, do not remove the cover from the device or attempt to dismantle it. Opening or removing covers may expose you to dangerous voltage levels. Equally, incorrect reassembly could cause electric shock on re-use of the appliance.
3. Do not expose the device to Fire, direct sunlight or excessive heat.
4. Do not expose the device to rain or moisture and do not allow it to come into contact with water.
5. Do not install the device in an environment likely to present a THREAT OF IMPACT.
6. You may clean the device using a fine damp cloth. Never use solvents (such as trichloroethylene or acetone), which may damage the device's plastic surface. Never spray the device with any cleaning product whatsoever.
7. The device is designed to work in temperatures from -40°C to 80°C.

8. The device must be installed at least 1 meter from radio frequency equipment, such as TVs, radios, hi-fi or video equipment (which radiate electromagnetic fields).
9. Do not attempt to upgrade device in an unstable power environment. This could cause unexpected issues.
10. Do not work on the system or connect or disconnect cables during lightning storms.
11. Children do not recognize the risks of electrical appliances. Therefore use or keep the device only under supervision of adults or out of the reach from children.
12. No repair can be performed by the end user, if you experience trouble with this equipment, for repair or warranty information, please contact your supplier.

Contents

Introduction	5
Setting up the Smart Monitor System	6
1. Wiring the Devices	6
2. RS-485 wiring method	7
3. PM-300 PT/CT wiring method	9
4. Dimensions of devices.....	10
5. AG-300 Plus Views.....	10
6. PM-300 Views	11
7. TT-300 Views.....	12
8. VB-200ST/VB-200SC Views	13
9. Vibration gauge installation position (recommended)	13
10. Installation Precautions	15
11. Installation Reference	16
Device Settings.....	19
1. Network Settings	19
2. Account Settings.....	20
3. Electromechanical equipment configuration	22
4. TT-300 Settings	24
5. VB200 Settings	26
6. ElecMeter (PM-300) Settings	30
7. Wireless setup	33
7.1 The wireless AP mode configuration (WiFi mode setup)	33
7.2 WiFi mode setting.....	38
8. Hardware Settings	42
The setting instructions of Teco inverter and Tecom AG-300 Plus Gateway	44
The App Software Operation	46

Introduction

The Tecom Smart Monitor System includes e-Gateway AG-300 Plus, Temperature Transducer TT-300, Accelerometer VB-200 and Multi-function Power Meter PM-300 and so on. It is suitable for measuring the temperature, vibration and many power data in the power panel, electromechanical, rotational mechanical market. Tecom Smart Monitor System can benefit you easy to manage your manufacture electromechanical devices, make sure your equipment is in a healthy state and prevent catastrophic downtime.

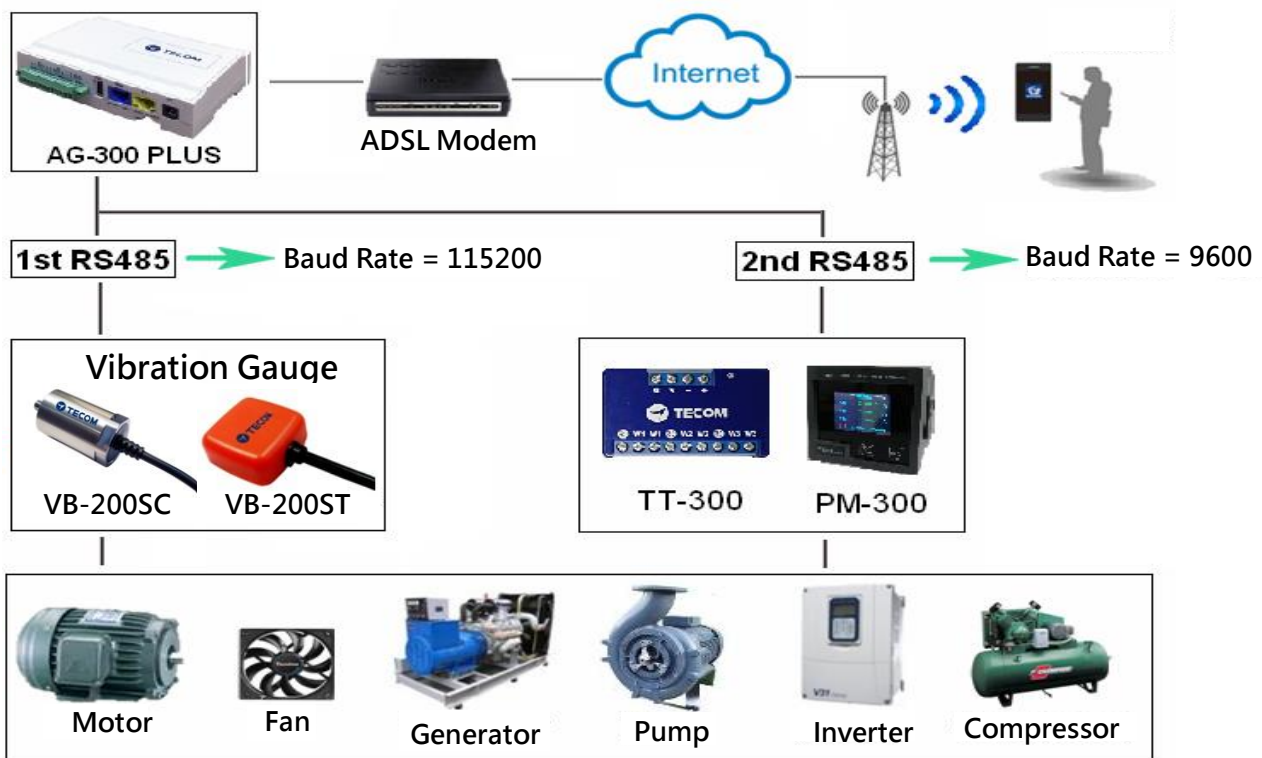

Tecom Smart Monitor System series products are shown as follows:

Product	MMK-Motor (MMK-2000)	MMK-SGR (MMK-2100)	Vibration Gauge -ST (MMK-2200)	Vibration Gauge -SC (MMK-2210)	Temperature Gauge (MMK-2300)
Content	AG-300 Plus x 1 PM-300 x 1 TT-300 x 1 TS-200 x 2 VB-200ST x 1	AG-300 Plus x 1 PM-300 x 1 TT-300 x 2 TS-200 x 4	AG-300 Plus x 1 VB-200ST x 1	AG-300 Plus x 1 VB-200SC x 1	AG-300 Plus x 1 TT-300 x 1 TS-200 x 3

This manual provides instructions for operating the MMK-Motor (MMK-2000) and MMK-Panel (MMK-2100).

Setting up the Smart Monitor System

1. Wiring the Devices

After unpacking the product package box, please connect the devices by following the connection figure as shown in below figure.

- A. The AG-300 Plus WAN port (blue) connects to the ADSL modem LAN port via the network cable.
- B. The AG-300 Plus is connected to the TT-300 and VB-200 or three-phase meters (PM-300) via RS-485.
- C. AG-300 Plus LAN port (yellow) Connect to PC via network cable. (For setup only)

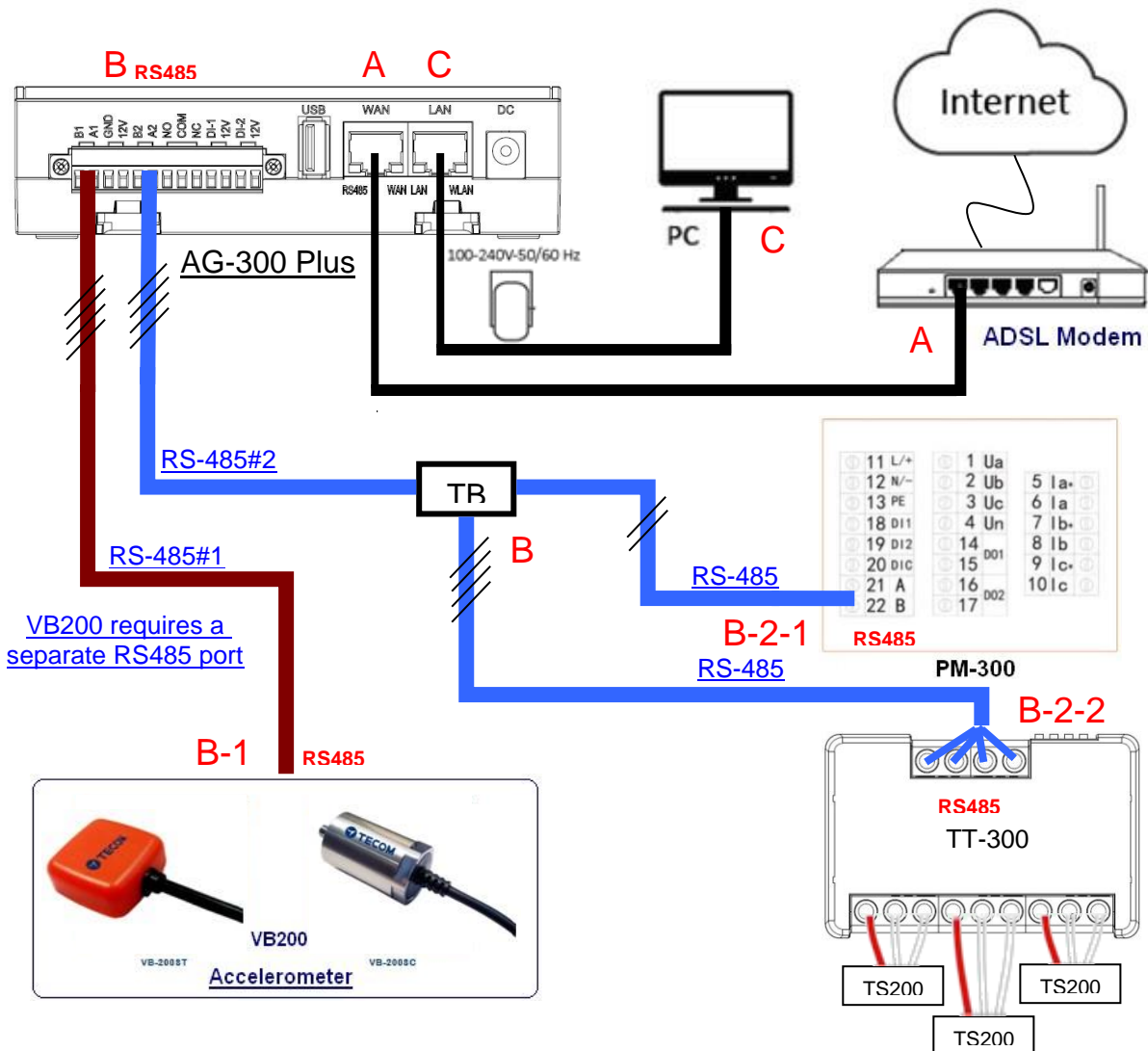

2. RS-485 wiring method

(1) AG-300 Plus

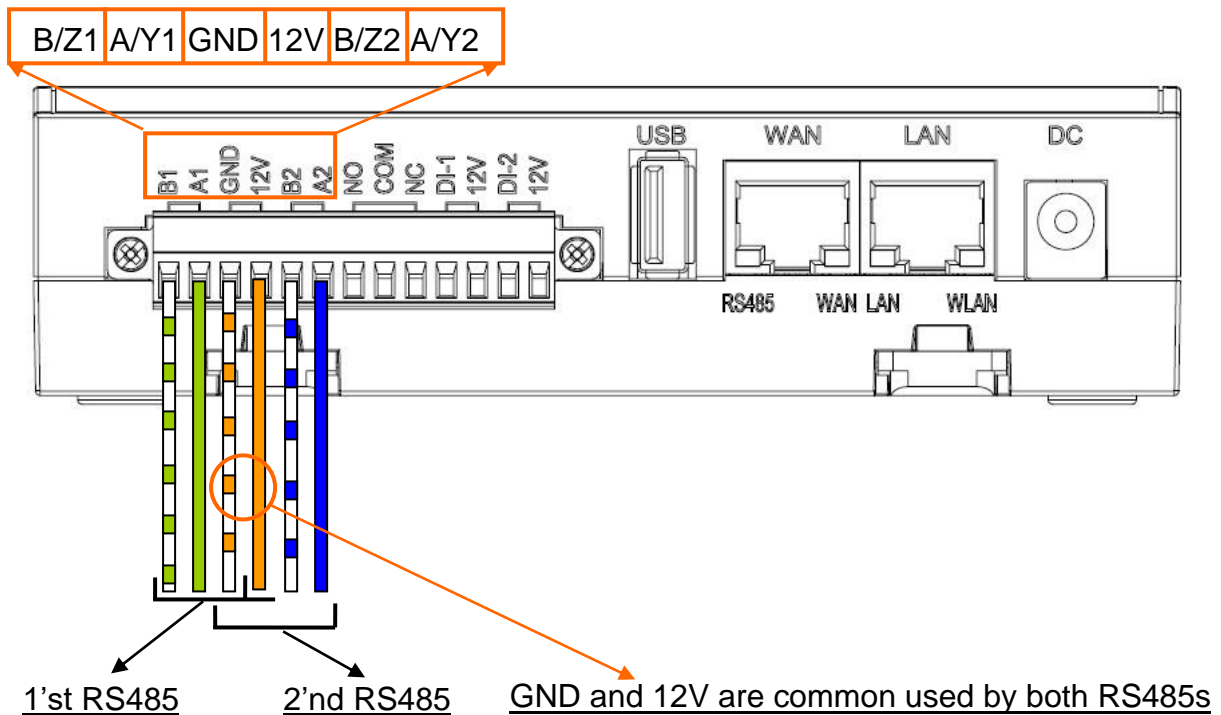

(2) TT-300

- A. Connect TT-300 to AG-300 Plus by using CAT5e (or CAT6) cable.
- B. Total two twisted pairs of CAT5e cable are used; one twisted pair for RS485 signal, and the other twist pair would be used for power and ground.

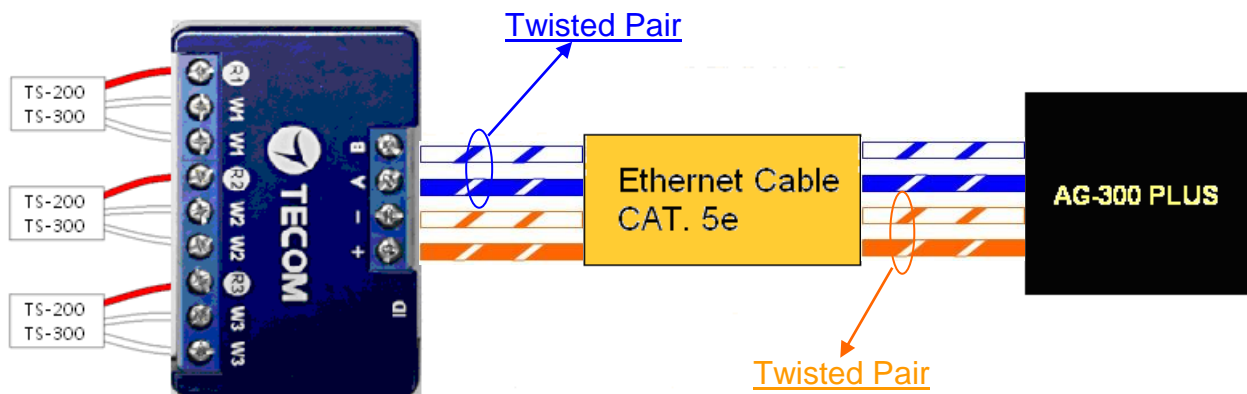
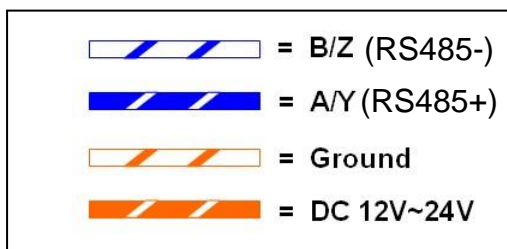

(3) VB-200ST/VB-200SC

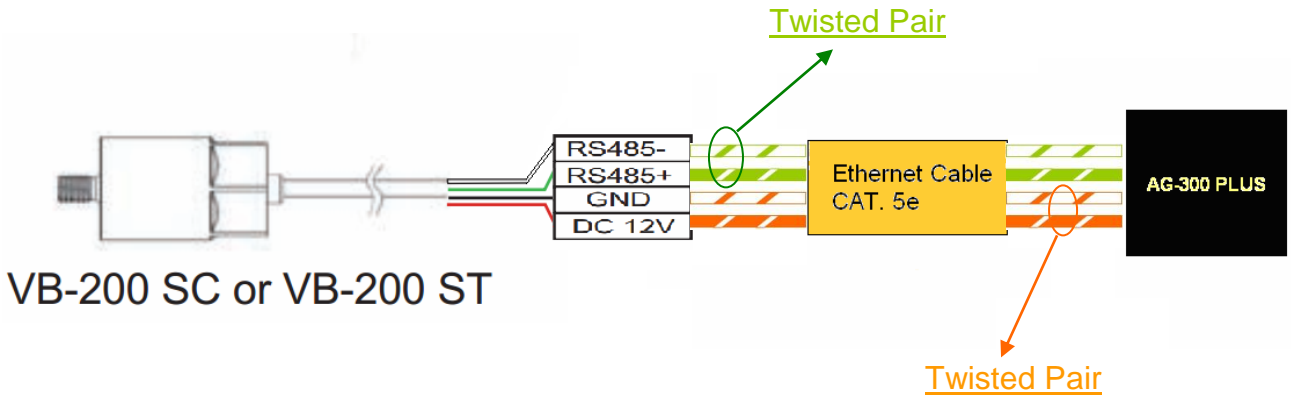

(4) PM-300

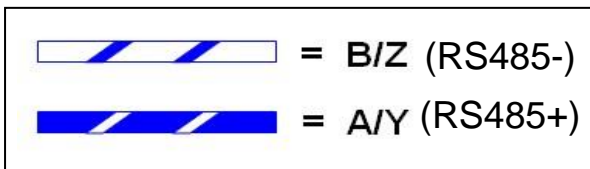

11 L/+	1 Ua	5 Ia
12 N/-	2 Ub	6 Ib
13 PE	3 Uc	7 Ib
18 D11	4 Un	8 Ib
19 D12	14 001	9 Ic
20 D1C	15 002	10 Ic
21 A	16	
22 B	17	

The Pin Assignment of Terminal

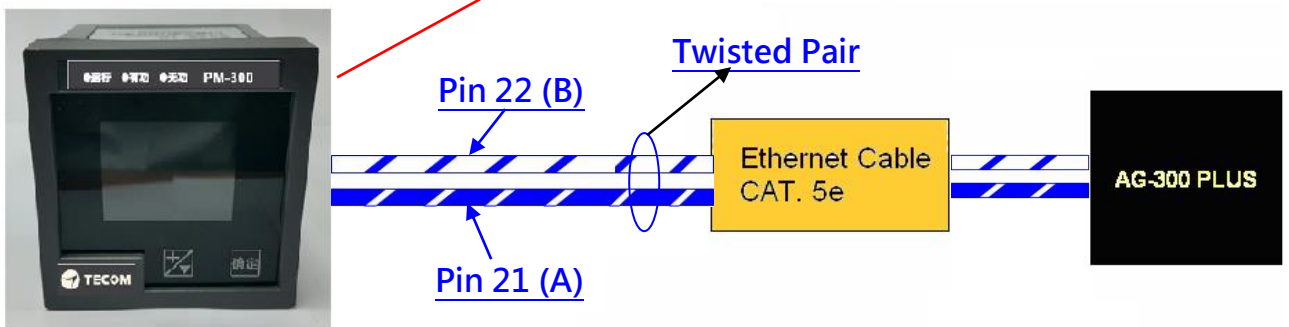

3. PM-300 PT/CT wiring method



Attention and warnings

- (1) It is prohibited to carry out wiring work during power is on line.
- (2) After the input power cut OFF, do not touch the circuit or change the wiring before the status P LED of PM-300 went off.
- (3) The $I_a/I_b/I_c$ & $I_a^*/I_b^*/I_c^*$ input terminals for current measurement and $U_a/U_b/U_c/U_n$ input terminals for voltage measurement MUST NOT be inter-connected.
- (4) Please refer to the following wiring connection for integrating CT and PT together.
- (5) After the completion of wiring, Power ON can only be conducted after the confirmation together with the on-site electricians.

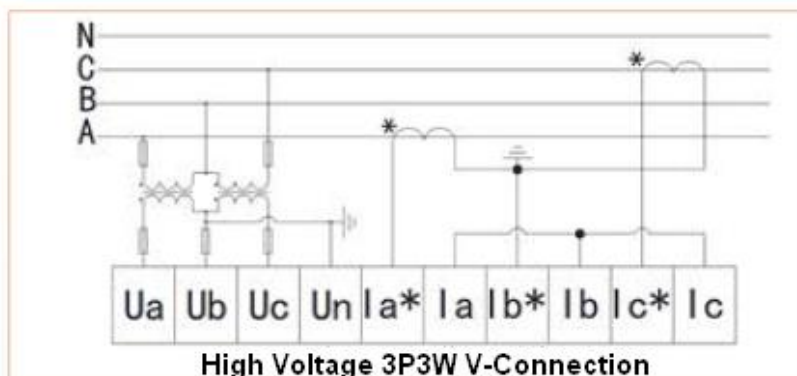
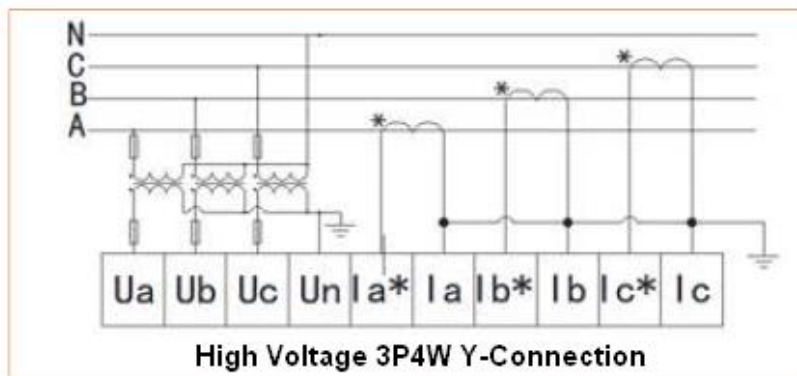
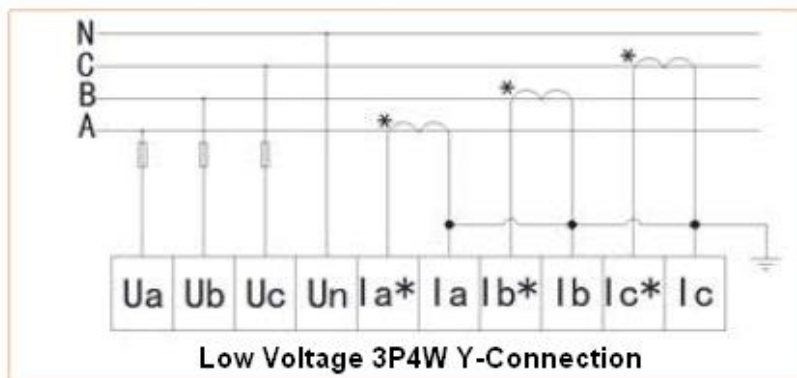



The Pin Assignment of Terminal

4. Dimensions of devices

- (1) AG-300 Plus dimensions : 130mm (L) x 99mm (W) x 36 mm (H)
- (2) PM-300 dimension : 72mm (L) x 72mm(W) x 86mm (H)
- (3) TT-300 dimension : 59mm (L) x 36mm(W) x 16mm (H)
- (4) VB-200ST dimensions : 30.5mm (L) x 30.5mm (W) x 11.5mm (H)
- (5) VB-200SC dimensions : Ø24.5 * 40.0 mm

5. AG-300 Plus Views

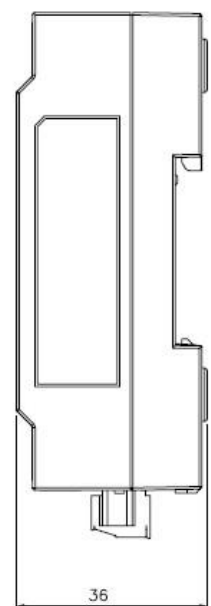
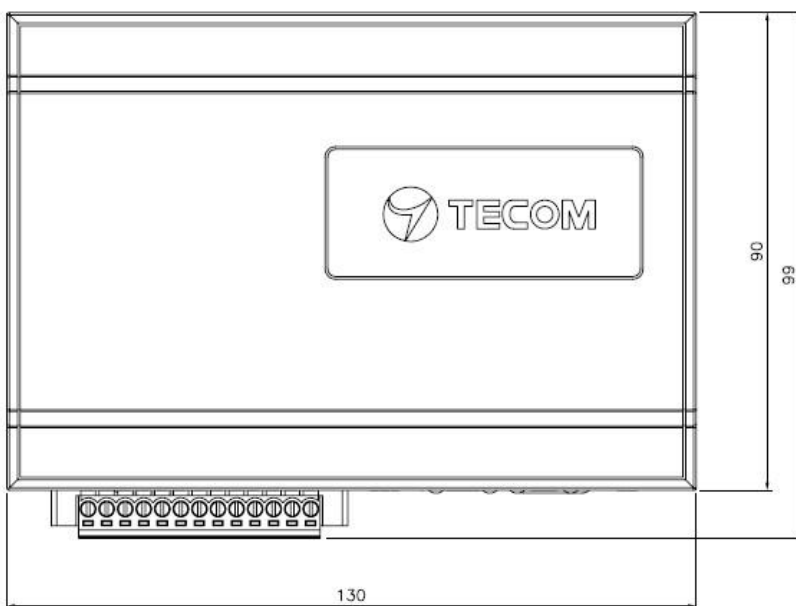

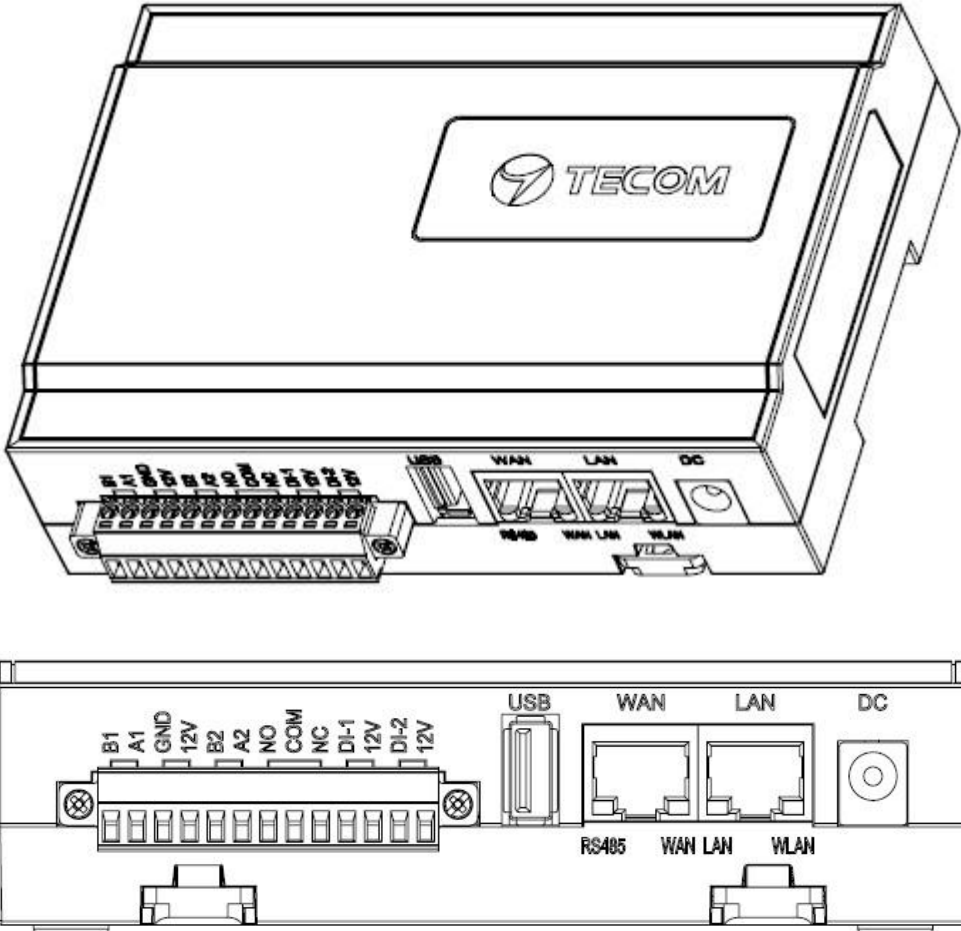

6. PM-300 Views

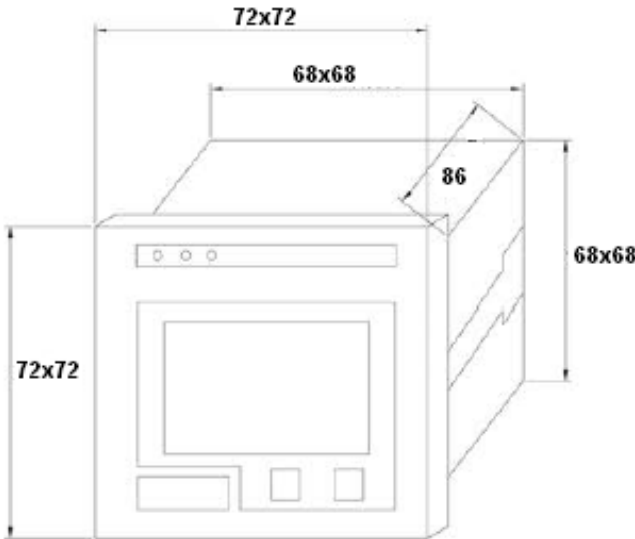

7. TT-300 Views

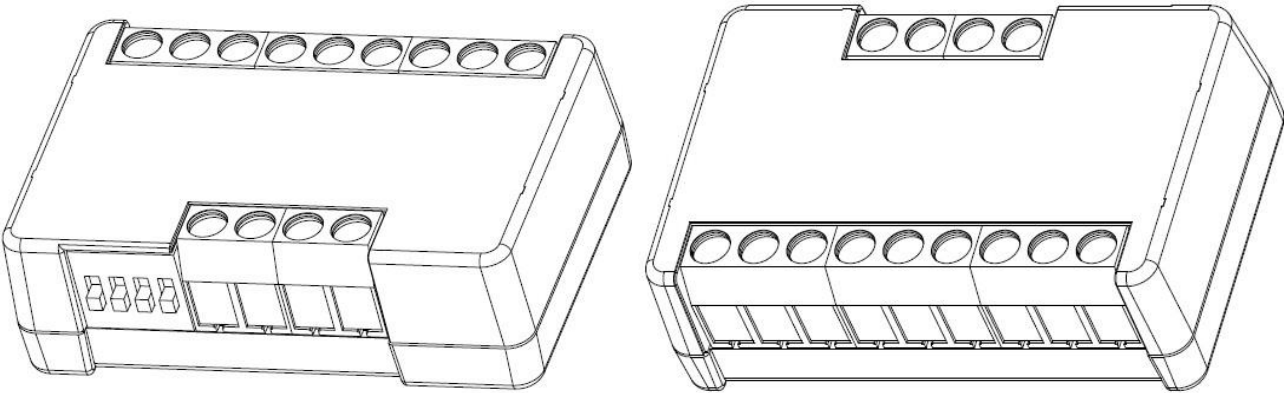
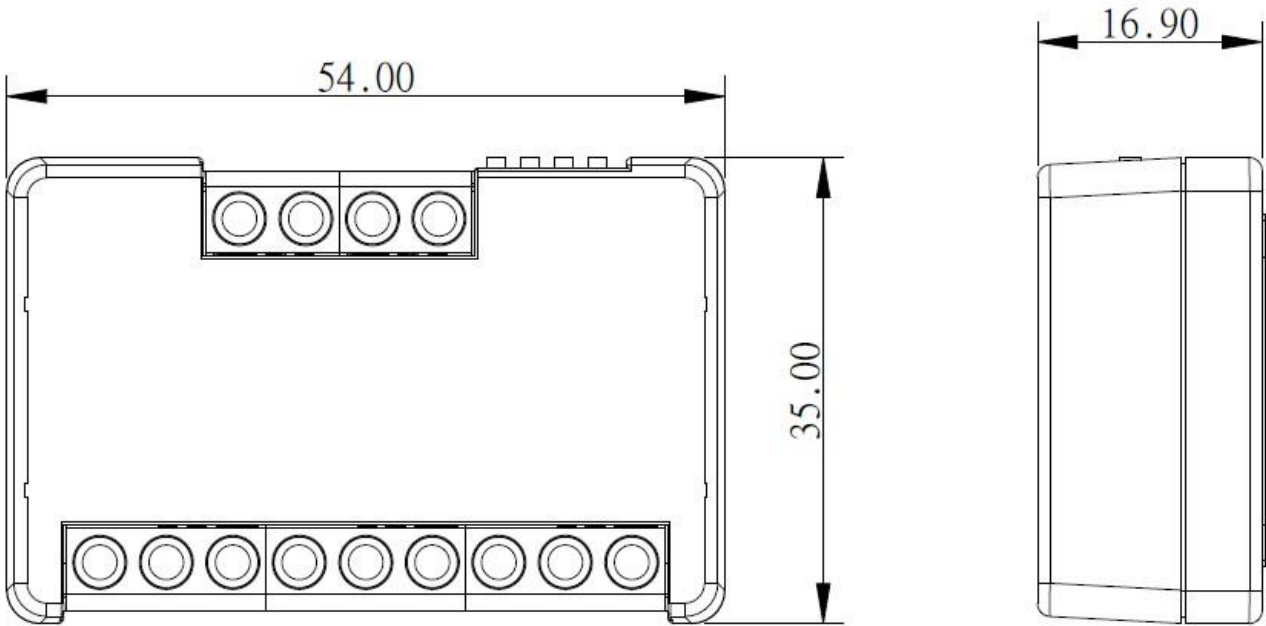

8. VB-200ST/VB-200SC Views

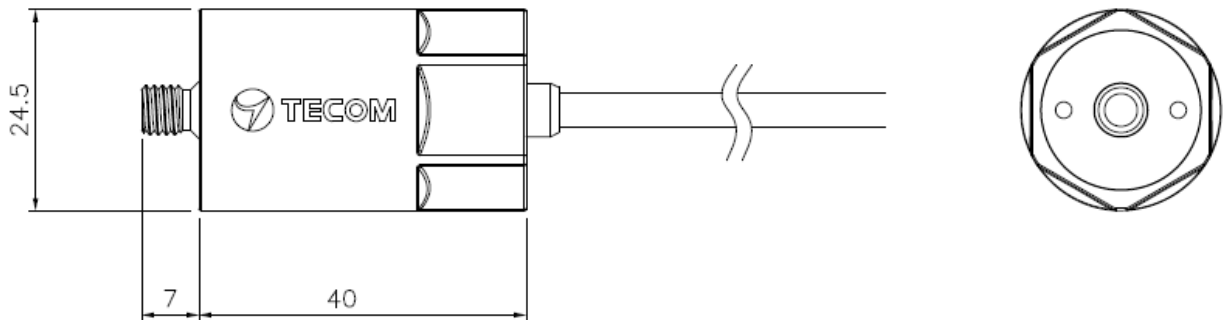

VB-200SC

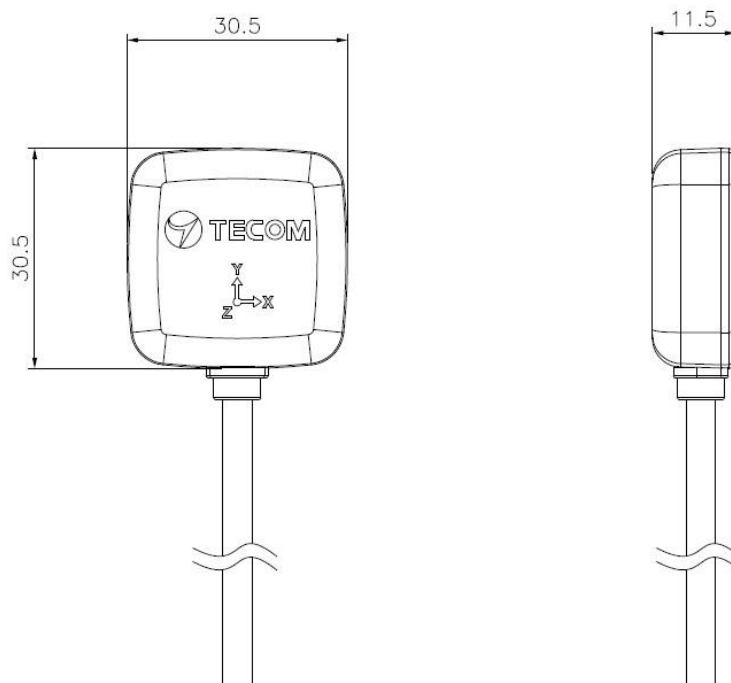

VB-200ST

9. Vibration gauge installation position (recommended)

Vibration measurement must observe the following rules according to ISO-10816 standard.

1. Close to the bearing
2. In direction either vertical or horizontal rather than 45-degrees or tilted direction
3. See diagram below for recommended installation position where the arrow symbol indicates direction and letter "x" the installation position.

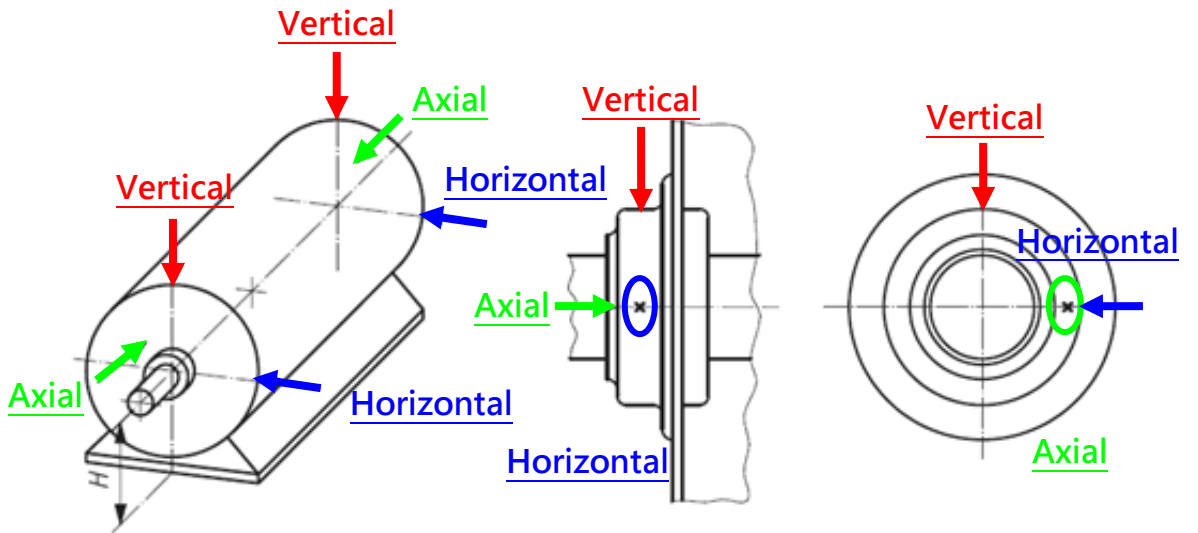

3 Axials X/Y/Z Position

3 Axials X/Y/Z Installation Location

Vibration gauge 3-axis direction

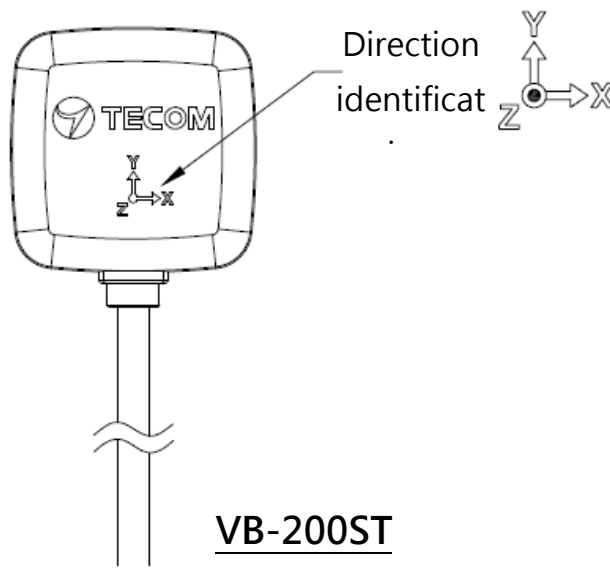

VB-200ST

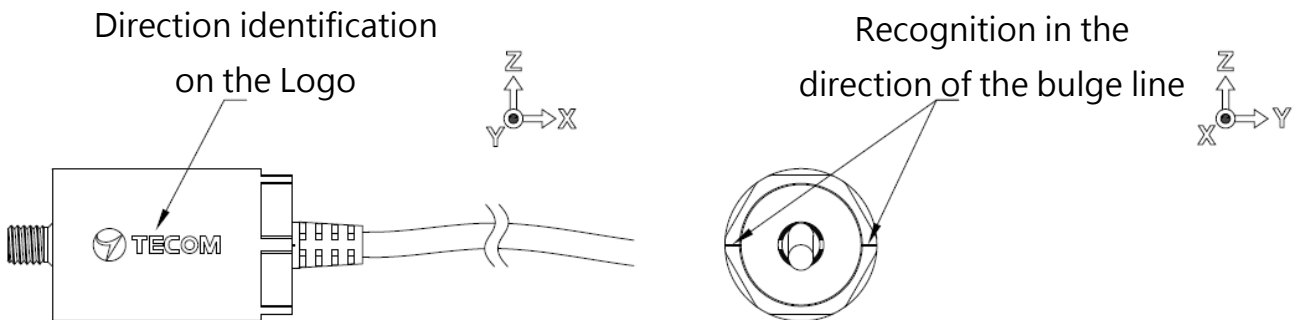

VB-200SC

10. Installation Precautions

- (1) VB-200SC is only suitable for installation with screw holes. If you want to add magnet, please use VB-200ST instead.
- (2) VB-200ST original magnet on the surface of the flatness requirements, can not be used in the cylindrical motor. It must use a two-legged magnet on VB-200ST, please call your representative for this application.
- (3) VB-200ST double-sided adhesive thickness is 0.6 mm, so paste the surface smooth enough to flat, convex part must less than 0.3 mm, slightly smaller pits do not affect.
- (4) The vibration gauge wire must be loosened. The wire close to the vibration gauge body can not be tightened. Therefore, pay attention when handling the wire, and leave some flexibility to allow the wire to move freely without affecting the vibration.
- (5) After vibration gauge installation is completed, you can shake the vibration gauge by hand, the vibration gauge must be very solid, no shaking phenomenon, otherwise the vibration value will increase, but also increases the frequency of unpredictable. In practice, the vibrating gauge mounted with a magnet will be secured with a quick-drying glue.
- (6) The point of installation must be thick steel, such as a motor body. Do not install on fan covers or heat sink fins or thin iron plates because they are too thin and easy to resonate, vibration values increase, and produce unexpected frequencies.
- (7) Generally, the vibration value will be less than 10 mm / s. If the vibration of the motor itself is not large and the vibration value is large, please re-check if the installation point and the vibration gauge are installed securely.
- (8) This vibration frequency response frequency range is 1-1130Hz, the speed of 200Hz and below (inclusive) of the motor is very applicable, because we can observe five times the frequency. If the rotation speed of the rotating machine exceeds 500Hz, only double the frequency can be observed. This vibration mode is not applicable. If the rotation speed of the rotating machine is lower than 10Hz, the low frequency part must be specially treated, please use the low frequency vibration gauge instead.

11. Installation Reference

11-1 Vertical

When the vibration gauge is installed in the vertical direction, it should be placed just above the rotating shaft. At this time, the Z-axis of the vibration gauge is the vertical direction. Please note that the two legs of the magnet are parallel to the rotating shaft so that they can be fixed on the arc surface of the motor on.

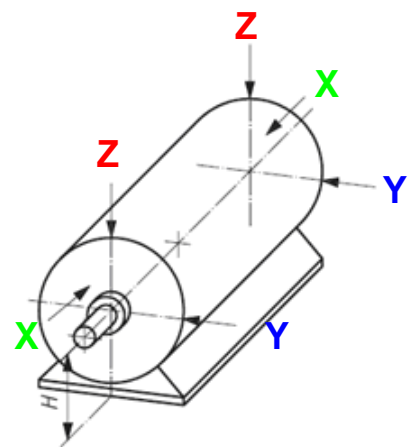
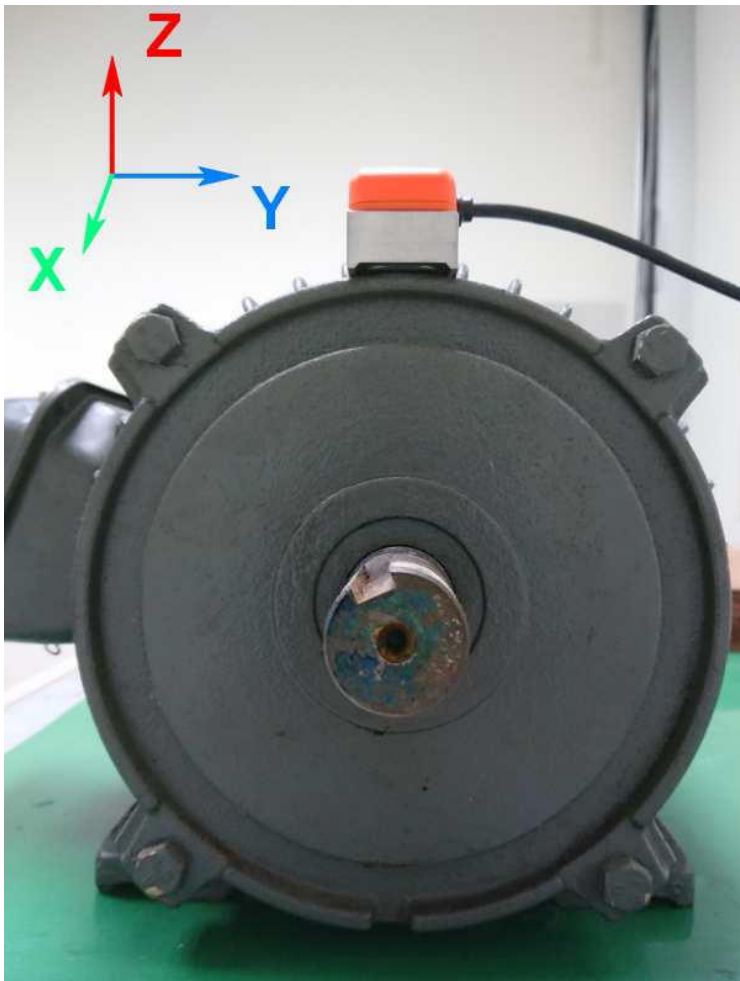

When using the vertical installation position, the figure represents the measured correct X. Y. Z vibration axis.

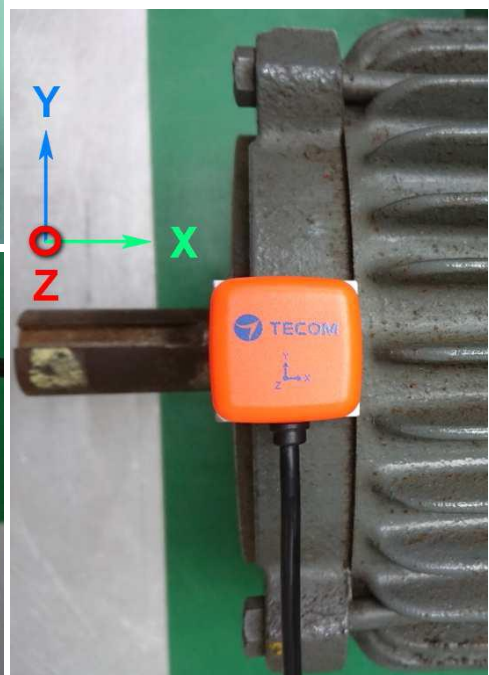
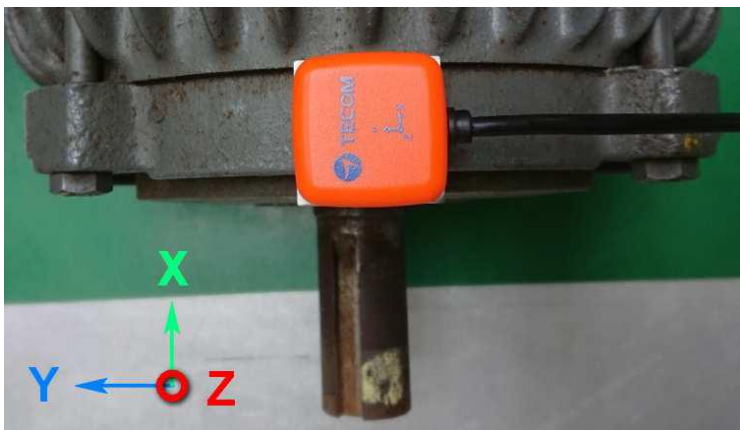

11-2 Horizontal

When the vibration gauge is installed in the horizontal direction, it should be placed on the level of the rotation axis, does not put too high, so as not to increase the vibration value. Put the higher position, the greater the value of the horizontal vibration. At this time, the Z axis of the vibration gauge is the horizontal direction. If you measure only one point, it is recommended to use this point. Vibration measurement of the vertical direction, to be placed on top of the rotating shaft, then the vibration of the Z-axis is the vertical direction, please note that the two legs of the magnet parallel to the axis of rotation, it can be fixed in the motor arc on.

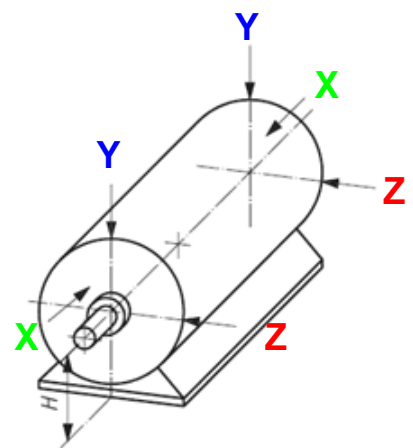
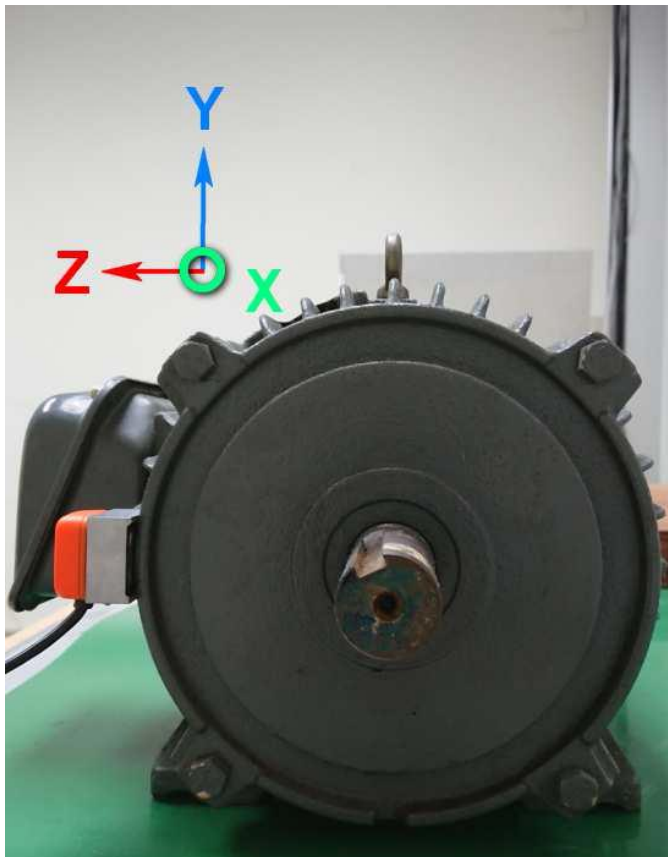

When using a horizontal mounting position, the figure represents the correct measured axial direction of vibration.

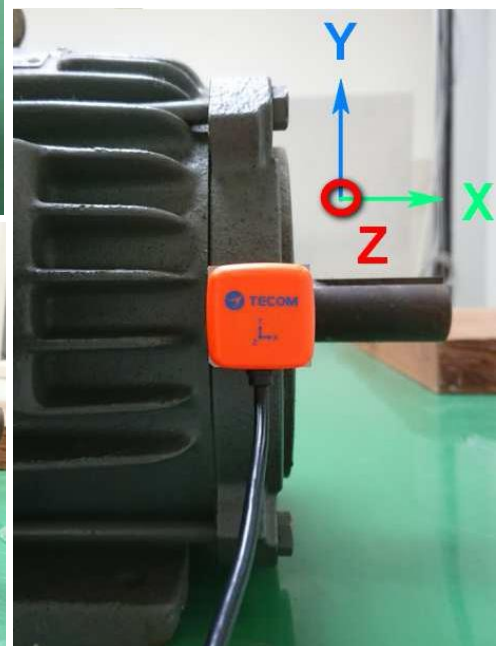
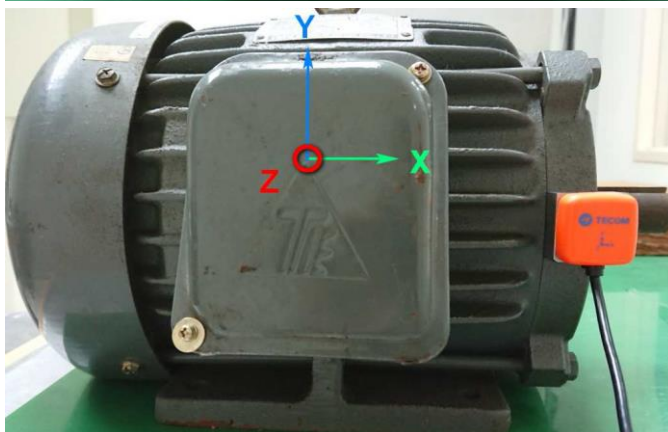

11-3 Axial

When the vibration gauge measurement value is the axial direction, it must be placed on the level of the rotation axis, do not put too high, so as not to increase the vibration value. Put the higher position, the greater the value of the horizontal vibration. At this time, the Z axis of the vibration gauge is the horizontal direction. If you measure only one point, it is recommended to use this point. Vibration measurement of the vertical direction, to be placed on top of the rotating shaft, then the vibration of the Z-axis is the vertical direction, please note that the two legs of the magnet parallel to the axis of rotation, it can be fixed in the motor arc on.

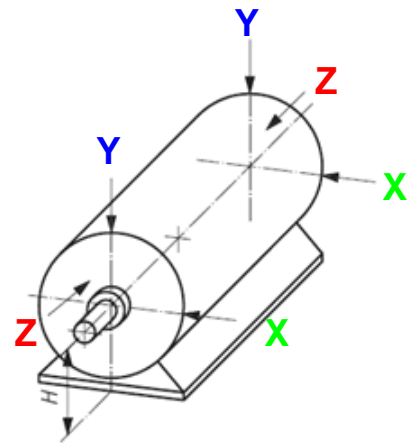

When using the axial installation position, the figure represents the measured correct vibration axis.

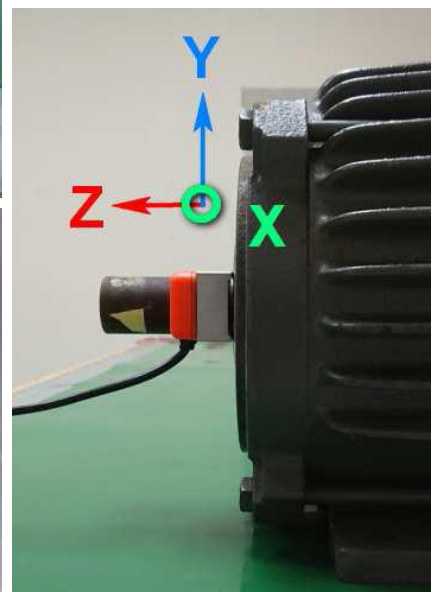
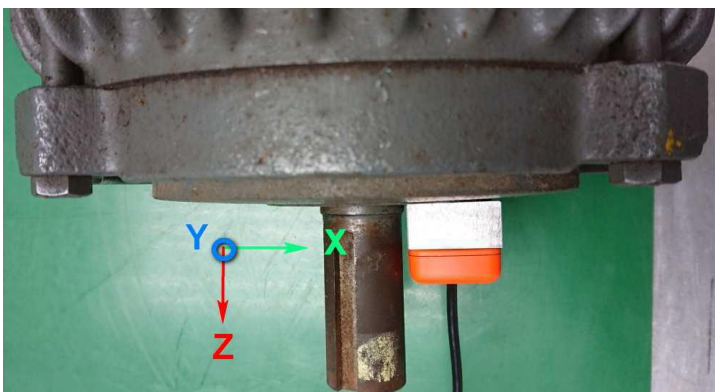

Device Settings

1. Network Settings

Step 1

- Make sure your PC/NB and the AG-300 Plus e-Gateway are in the same LAN (Recommended to use DHCP on your PC/NB)
- Connect an Ethernet cable point-to-point between Notebook/PC and AG-300 Plus (LAN Port)
- Connect the power adapter to AG-300 Plus
- The computer opens the browser, and the address bar enters the AG-300 Plus setup page URL <http://192.168.168.10>
- Enter the user name: admin
- Password: IP585xAdmin,
- Click OK.



Step 2

(if the network is DHCP plug and play, you can omit this step)

- In the left main menu click to use the 【Settings】 → 【WAN Settings】 .
- Please select 【STATIC (fixed IP)】 in the WAN Connection Type Pull-down menu.

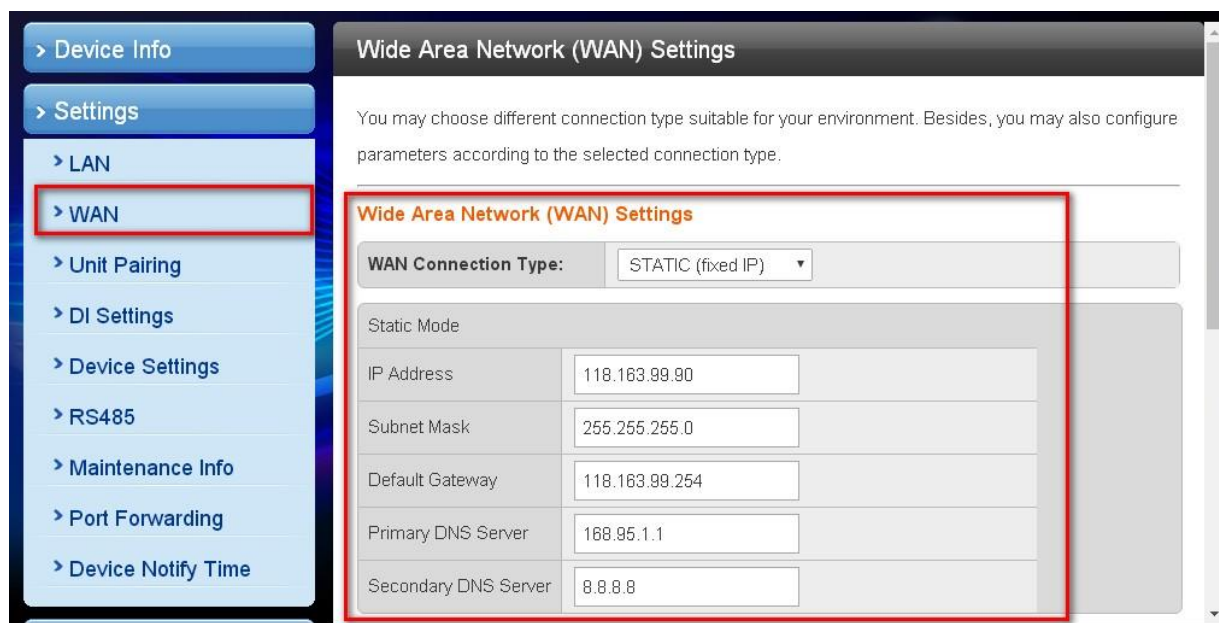

- IP Address: Please enter the IP address information.
- Subnet mask: Please enter subnet mask information.
- Default Gateway: Please enter the preset gateway information.
- Primary DNS Server: Primary DNS Server Information.
- Secondary DNS server: Secondary DNS server information.
- Please click the 【Apply】 button at the bottom of the page.

After the WAN Settings is completed, please use the browser to try to open the edition.cnn.com, www.yahoo.com.tw and other pages, if the smooth opening means that the external network function is normal.

If have firewall management, Please use the mobile phone APP communication port by TCP 53100 ~ 53199.

2. Account Settings

Step 1

Click on the left main menu to use the 【Settings】 → 【Unit Pairing 】, and then click the 【Add】 button.

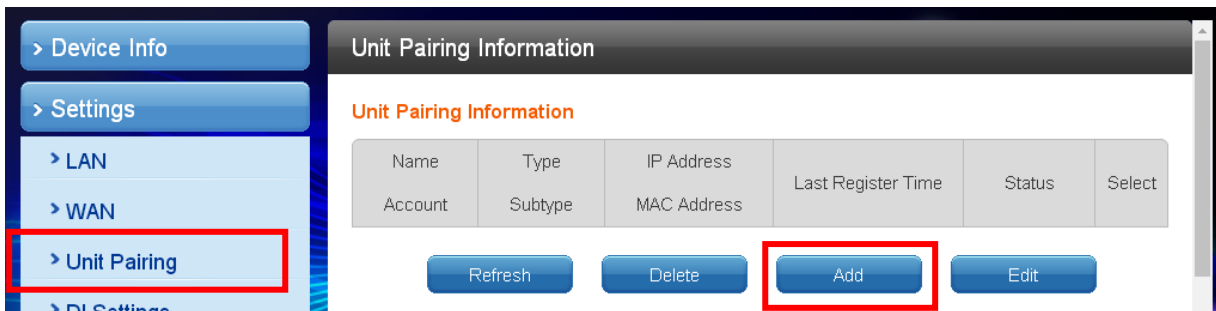

Step 2

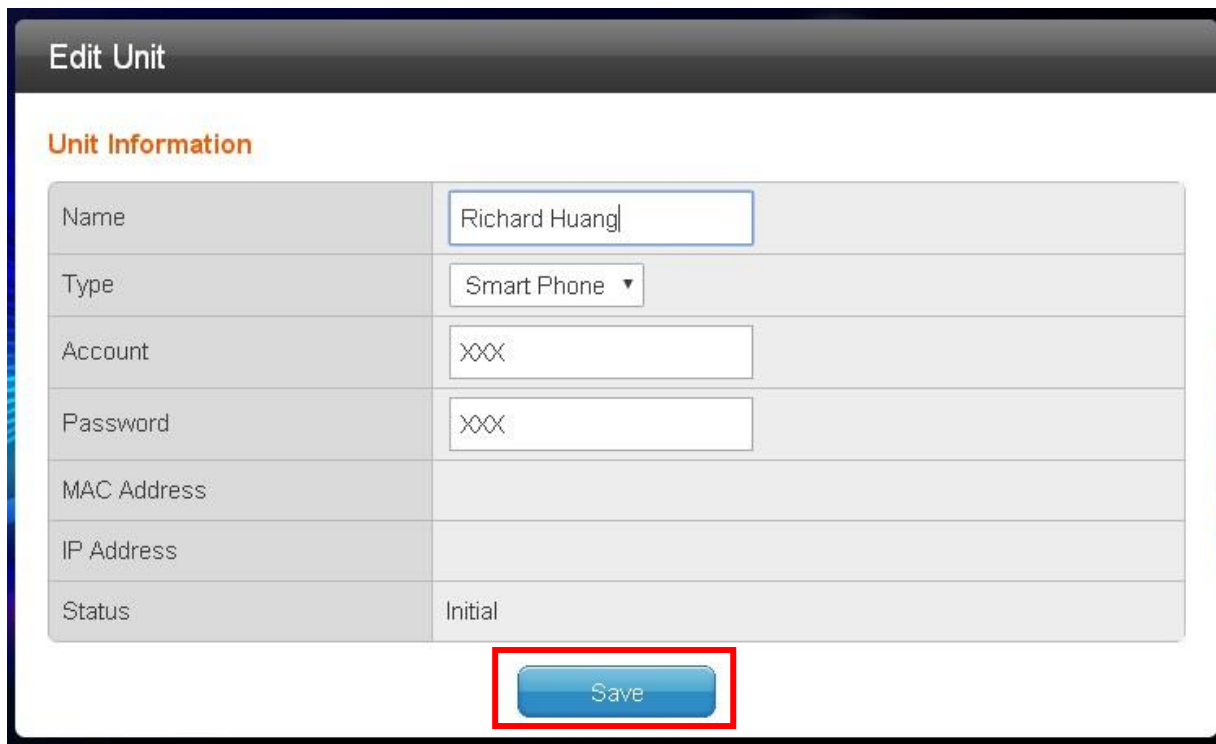
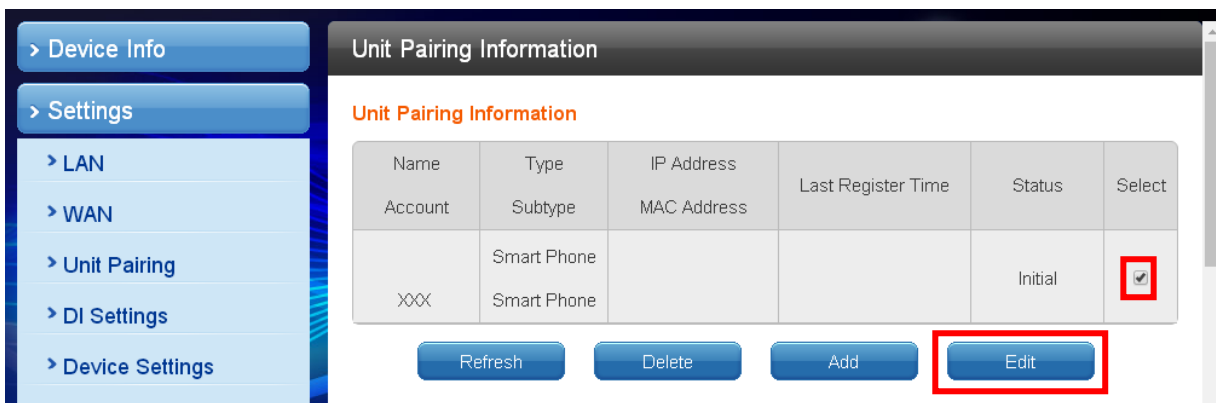

- Name: Please enter your name.
- Account: 100 (account number 100-119 total 20 groups).

- Password: Please enter your personal password (recommended account number).
- When the setting is completed, click the **【Save】** button below.
- Please click the **【Start Pairing】** to complete the account settings.

Edit Unit

Unit Information

Name	Richard Huang
Type	Smart Phone
Account	100
Password	100
MAC Address	
IP Address	
Status	Configured

Buttons: Save, **Start Pairing**, Stop Pairing

3. Electromechanical equipment configuration

Step 1

- Click on the left main menu to use the **【Settings】** → **【RS485】** .
- On the right RS485 select the motor or switchboard, then click Add.
- The following is a motor example for reference.

RS485

Motor

Index	Start Address	Name	Work ID	Work Status	Select
1	30001	Motor - Vibration	VB200	Stop	<input type="checkbox"/>

Buttons: Delete, **Add**, Edit

Switchgear

Index	Start Address	Name	Work ID	Work Status	Select
-------	---------------	------	---------	-------------	--------

Buttons: Delete, Add, Edit

Step 2

Motor configuration table

Motor	
Name	<input type="text"/>
Work ID	<input type="text"/>
Voltage	<input type="text"/> V
Current	<input type="text"/> A
SPEC Power	<input type="text"/> KW
Poles	<input type="text"/>
Rotational Speed	<input type="text"/> RPM
Frequency	<input type="text"/> Hz
Efficiency	<input type="text"/> %
Maintenance Hours	<input type="text"/>
Control point	None ▾
FAE Information	There is not the FAE information
Engineer Information	There is not the engineer information

[Save](#)

- Name: Please define it yourself.
- Work ID: Please enter the motor number.
- Voltage: Please fill in the motor specifications.
- Current: Please fill in the motor specifications.
- SPEC Power: Please fill in according to motor specifications.
- Poles: Please fill in the motor specifications.
- Rotational Speed: Please fill in the motor specifications.
- Frequency: Please fill in the motor specifications.
- Efficiency: Please fill in the motor specifications.
- Control point: To support emergency shutdown, select DO at the drop-down menu.

(Emergency shutdowns function: When an emergency alarm occurs, the user controls the APP to make the AG300 through Digital Output signal to the alarm device shutdown).

Digital Output please refers to Note for wiring.

When the setting is complete, click the 【Save】 button below.

Back to 【RS485】 manual, click where you want to select an item (motor, Switchgear) check the "v", then click on the 【Edit】 button, enter the individual sensors (TT-300, VB-200, PM300 ...) page.

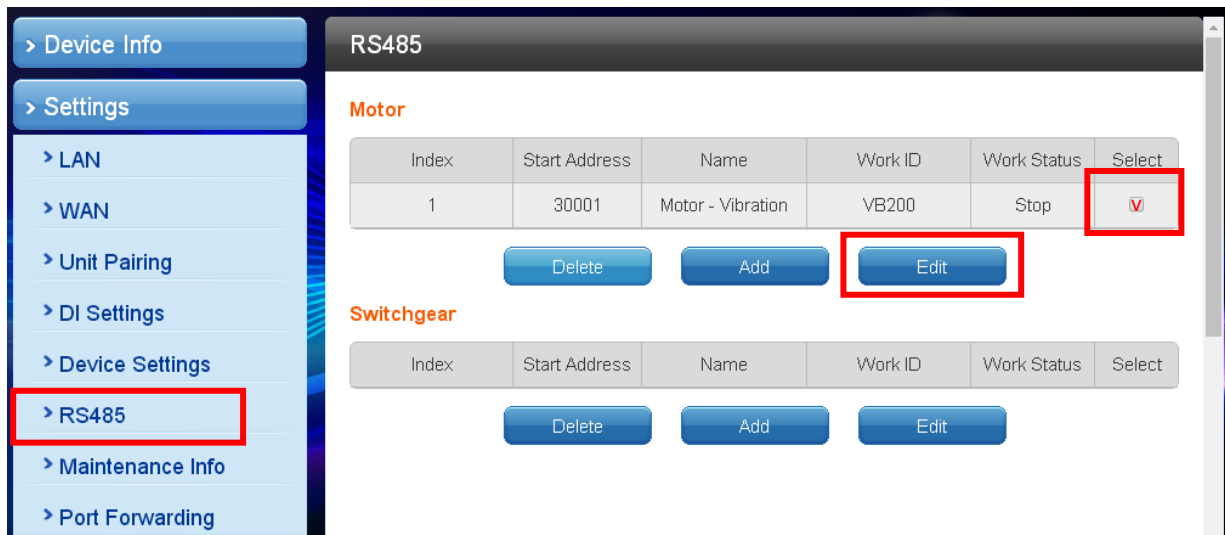

4. TT-300 Settings

The TT-300 itself is designed with 4-digit DIP switches on the hardware, representing RS485 ID 0 ~ 15 (please refer to Section 8 of the device settings). Please set the RS485 ID of Gateway AG-300 Plus with the corresponding TT-300 to the same RS485 ID.



- To add TT-300, please click the 【 + 】 button.

TT300

Line	2 ▾
RS485 ID	<input type="text"/>
Name	<input type="text"/>
Temperature1	
Name	<input type="text"/>
Type	None ▾
Limit	<input type="text"/> °C
Early Warning	<input type="text"/> °C
Low	<input type="text"/> °C
High	<input type="text"/> °C
Sudden Change	
Amplitude	<input type="text"/> °C
Time	5~60 s

- Line: Select to use line 1 or line 2, **(Please select line 2 for TT-300)**

- RS485 ID: Please fill in according to RS485 specification.

- Name: TT-300

Temperature 1/2/3

- Name: NDE / DE / R / S / T
- Limit: Temperature alarm value, please fill in the motor specifications.
- Early Warning: Temperature warning value, please fill in according to the motor specifications.
- Low: Minimum temperature, please fill in the motor specifications.
- High: Maximum temperature, please fill in the motor specifications.

Sudden Change

- Amplitude: Please fill in the degree according to the demand.
- Time: Please fill in the required values.

5. VB200 Settings

VB-200 Series Vibration gauge' s pre-set RS485 ID value is 15. If the same group of RS485 online to be connected to multiple VB-200 Series Vibration gauge, the installation method must be a VB-200 installation wiring and in accordance with the following steps to modify the RS485 ID on none-15 value (0 ~ 14), then can only be connected to the second set of VB-200 series vibration and set.

The purpose of setting only one VB-200 vibration gauge at a time is to avoid that if multiple VB-200s are connected to the AG-300 Plus at the same time, the preset RS485 ID value of whole VB-200 vibration gauges are the same (15), and hard to distinguish them. Not to avoid setting may be troublesome, please do according to a set to complete and then connect to another VB-200 series of vibration rules installation and setting.

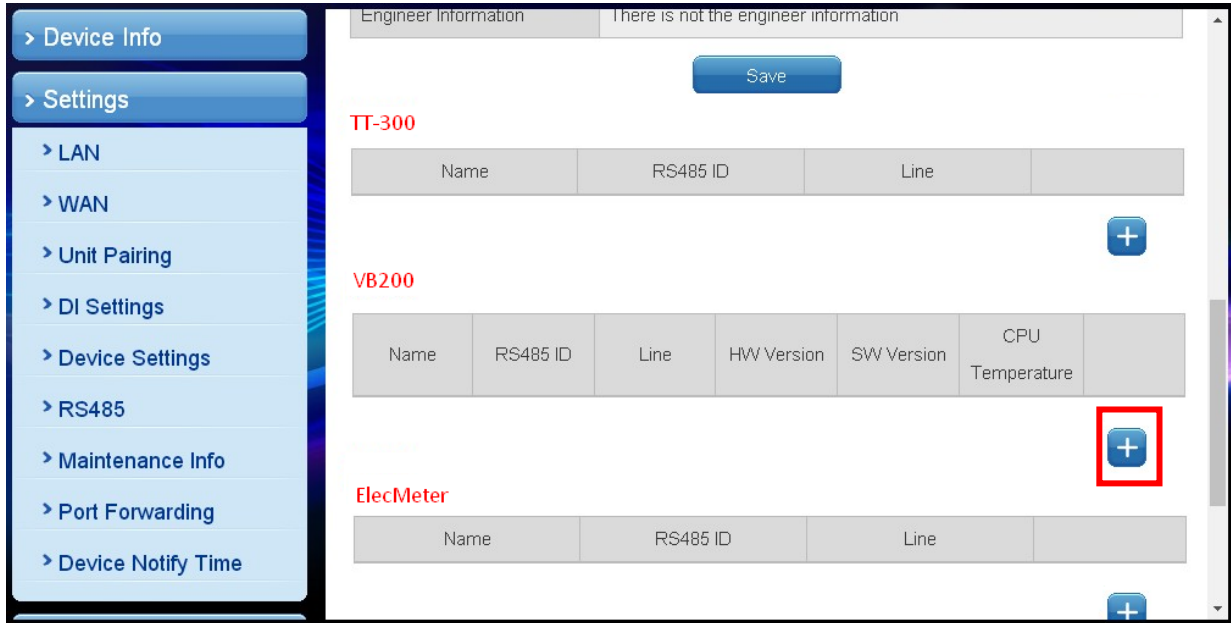

- To add VB200, please click the 【 + 】 button under VB200 Item.

VB200

Line	1 ▾
RS485 ID	<input type="text"/>
Name	<input type="text"/>
X	
Name	<input type="text"/>
Vibration	
Limit	<input type="text"/> mm/s
Early Warning	<input type="text"/> mm/s
Low	<input type="text"/> mm/s
High	<input type="text"/> mm/s
Sudden Change	
Amplitude	<input type="text"/> mm/s
Time	5~60 <input type="text"/> s

- Line: Select to use line 1 for VB-200 (Recommended).
- RS485 ID: Please fill in according to RS485 specification.
- Name: VB-200 or defined by user.

Vibration X / Y / Z

- Name: X / Y / Z

Vibration

- Limit: Vibration alarm value, please fill in the motor specifications.
- Early Warning: Vibration warning value, please fill in according to the motor specifications.
- Low: Minimum vibration value, please fill in the motor specifications.
- High: Maximum vibration value, please fill in the motor specifications.

Sudden Change

- Amplitude: Please fill in the required value (mm/s).
- Time: Please fill in the required values.

Modify VB-200 RS485 ID

Please follow the following steps to modify the RS-485 ID of VB-200.

The image shows two screenshots of the TECOM Smart Monitor System interface. The top screenshot displays the main menu on the left and a list of devices on the right. A yellow callout box points to the 'Modify' button (a blue square with a white pencil icon) for the VB-200 device in the list. The bottom screenshot shows the 'Modify' dialog box for VB-200, where the 'RS485 ID' field is highlighted with a red box and contains the value '14'. A yellow callout box points to the 'Save' button, which is also highlighted with a red box. A yellow arrow points from the 'Modify' button in the top screenshot to the 'Save' button in the bottom screenshot.

1. Select the modify button

VB200						
Name	RS485 ID	Line	HW Version	SW Version	CPU Temperature	
VB-200	15	0				

2. Modify VB-200's RS485 ID and press 【Save】 button

6. ElecMeter (PM-300) Settings

- To add ElecMeter, please click the 【 + 】 button under ElecMeter Item.
- To Select 【 PM300 】 in the Type field

ElecMeter

Line	2 ▾
RS485 ID	1
Name	PM-300
Type	PM300 ▾
Voltage 1	
Name	R
Up Limit	240 V
Up Early Warning	235 V
Down Limit	100 V
Down Early	105 V
Low	0 V
High	300 V
Sudden Change	
Amplitude	100 %
Time	60 s

- Line: Select to use line 1 or line 2, **(Please select line 2 for PM-300)**.
- RS485 ID: Please fill in according to RS485 specification.
- Name: PM-300 or defined by user.
- Type: Please Select PM300.

Voltage 1/2/3

- Name : Please specify phase R/S/T.
- Limit: Overvoltage alarm value, please fill in the motor specifications.
- Up Early Warning: Overvoltage warning value, please fill in according to the motor specifications.

- Down Limit: Under Voltage alarm value, please fill in the motor specifications.
- Down Early: Under Voltage warning value, please fill in the motor specifications.
- Low: Minimum voltage value, please fill in the specifications.
- High: Maximum voltage value, please fill in the specifications.

Sudden Change

- Amplitude: Please fill in the required values.
- Time: Please fill in the required values.

Current

Current 1	
Name	<input type="text" value="R"/>
Limit	<input type="text" value="330"/> A
Early Warning	<input type="text" value="320"/> A
Down Limit	<input type="text" value="0"/> A
Down Early	<input type="text" value="0"/> A
Low	<input type="text" value="0"/> A
High	<input type="text" value="400"/> A
Sudden Change	
Amplitude	<input type="text" value="100"/> %
Time	<input type="text" value="60"/> s

- Name : Please specify phase R/S/T.
- Limit: Over Current alarm value, please fill in the motor specifications.
- UP Early Warning: Over Current warning value, please fill in the motor specifications.
- Down Limit: Undercurrent alarm value, please fill in the motor specifications.
- Down Early: Undercurrent warning value, please fill in the motor specifications.
- Minimum: Please fill in according to motor specifications.
- Maximum: Please fill in the motor specifications.

Sudden Change

- Amplitude: Please fill in the required values.

- Time: Please fill in the required values.

Power

Power		
Limit	<input type="text" value="280"/>	KW
Early Warning	<input type="text" value="270"/>	KW
Low	<input type="text" value="0"/>	KW
High	<input type="text" value="500"/>	KW

Power factor		
Low	<input type="text" value="0"/>	
High	<input type="text" value="1"/>	

- Limit: Power alarm value, please fill in accordance with the motor specifications.
- Early Warning: Power warning value; please fill in accordance with the motor specifications.
- LOW: Low power value; please fill in accordance with the motor specifications.
- High: High power value; please fill in accordance with the motor specifications.

Power factor

- LOW: 0~1, please fill in accordance with the motor specifications.
- High: 0~1, please fill in accordance with the motor specifications.

7. Wireless setup

Designed for e-gateway AG-300 Plus hardware, the "wireless setup" page contains options of WiFi mode, "Basic", "Advanced", "Security", and "Station list".



You may set WiFi mode into "Wireless AP mode" and "Wireless client mode".

The wireless AP mode is an AP with gateway serving as WiFi access point.

The wireless client mode set the gateway as a client to connect to other WiFi AP.

7.1 The wireless AP mode configuration (WiFi mode setup)

7.1.1 Basic wireless settings

This option enables user to set up basic wireless communication parameters including network name and mode with WiFi function default to Enable. WiFi [Enable] page: see figure below:

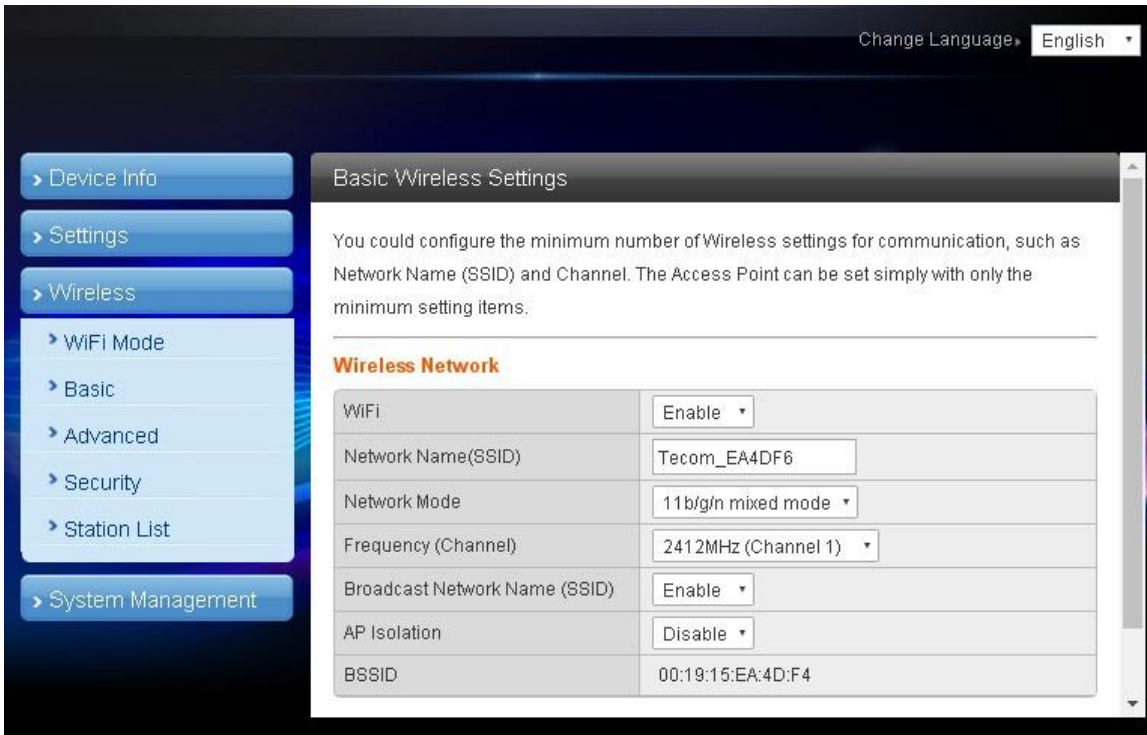

WiFi [Disable] page: see figure below:

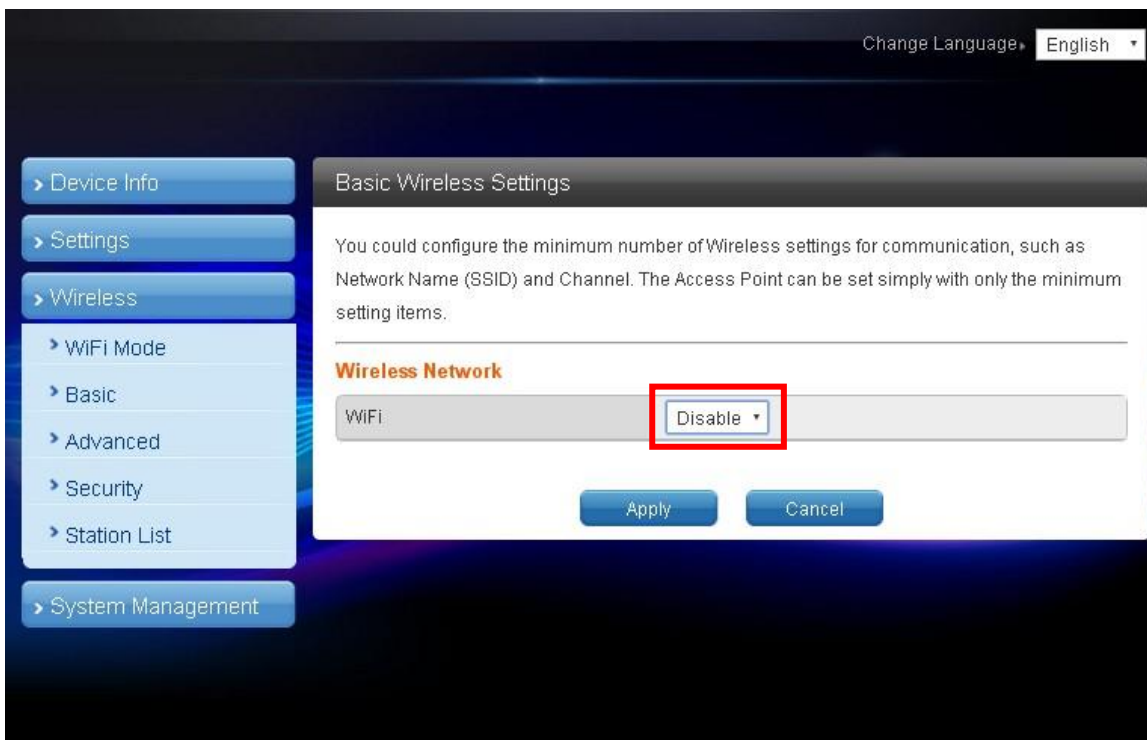

7.1.2 Advanced wireless settings

This option is aimed at setting up country/region and support channel with page as shown in figure below:

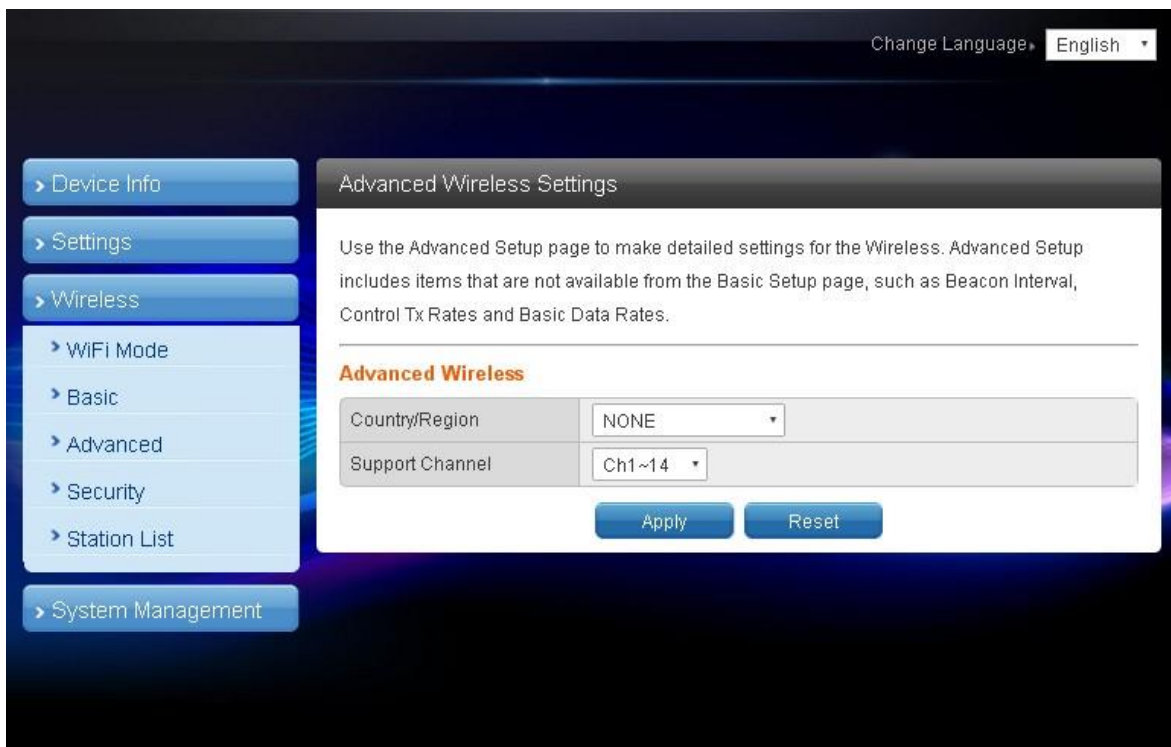

7.1.3 Wireless security/encryption settings

This option is aimed at setting up wireless security and encryption to prevent equipment access and monitoring without certification; available security modes are WPASKWPA2PSK and Disable with factory default set to the latter. See figure below for page of this option:

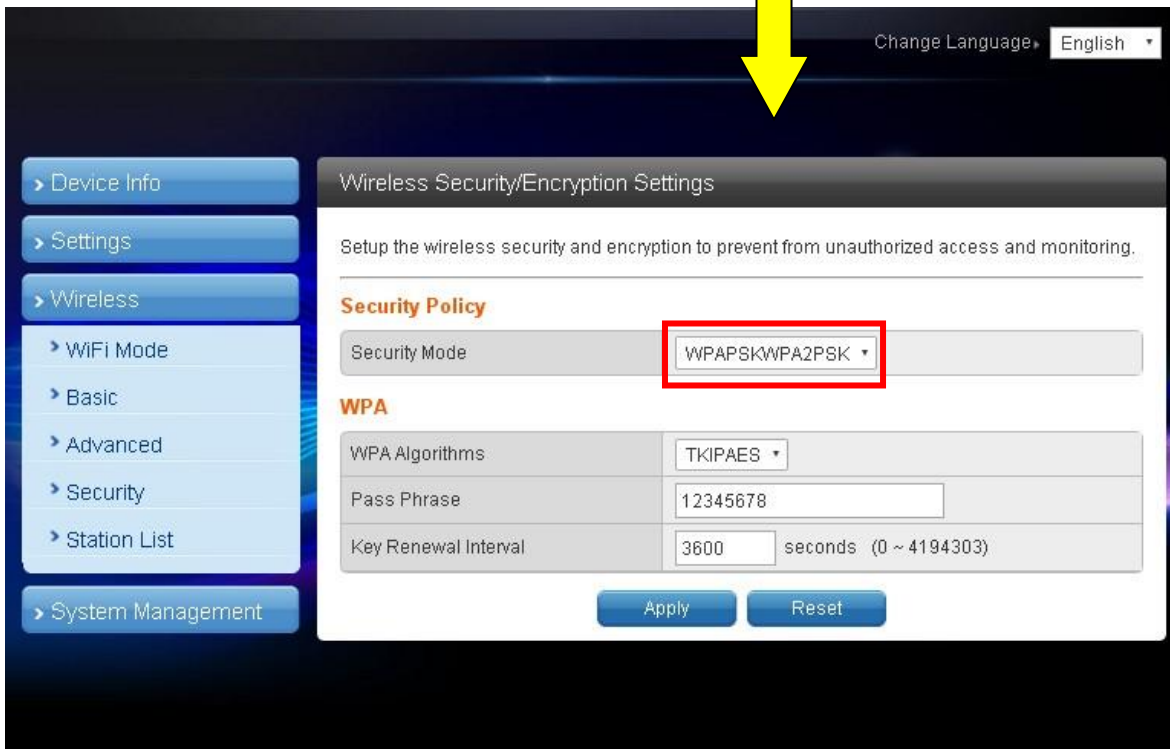
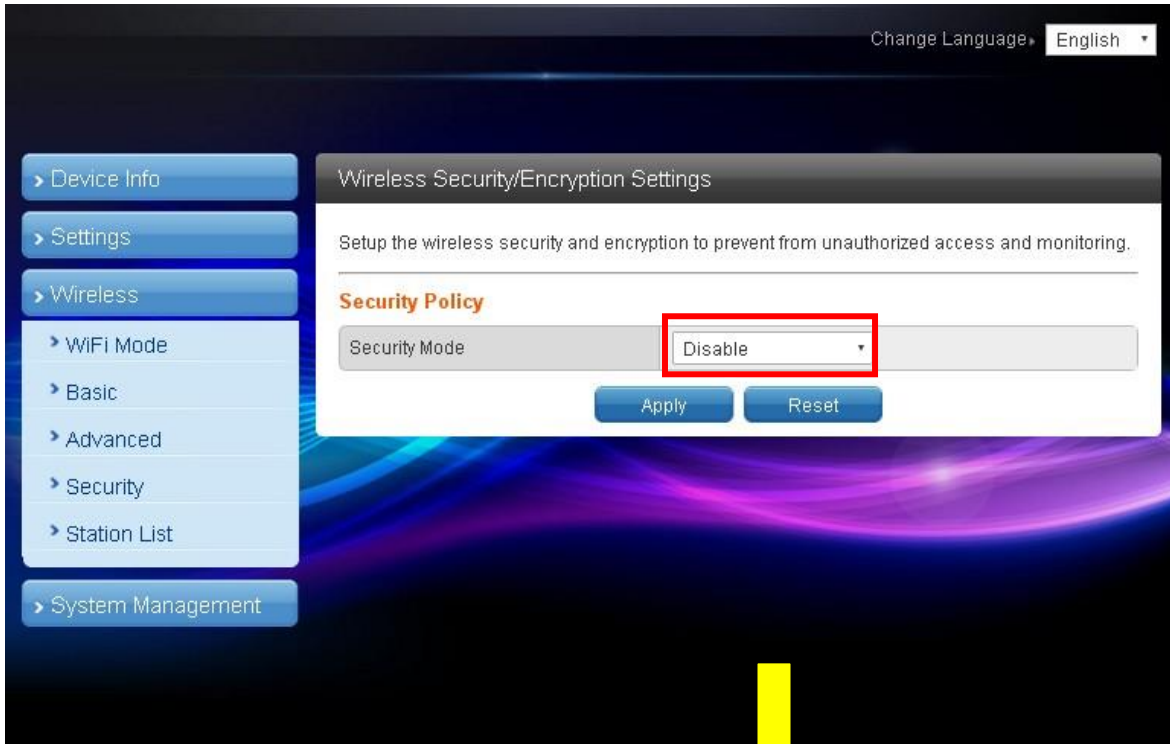

Set up WPA algorithm, pass phrase, and key renewal interval; once set up and saved successfully users are required to input pass phrase set up here to connect to WiFi.

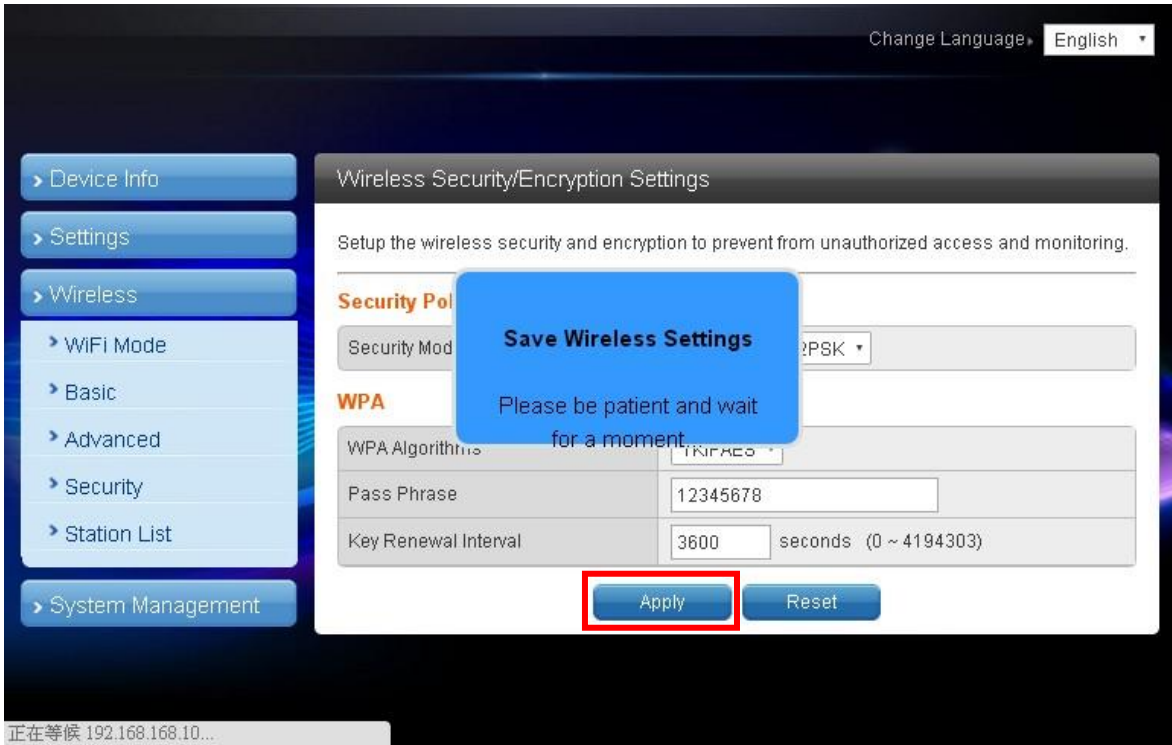

The client end is required to log in WiFi router of e-gateway AG-300 Plus2 with his/her smartphone:

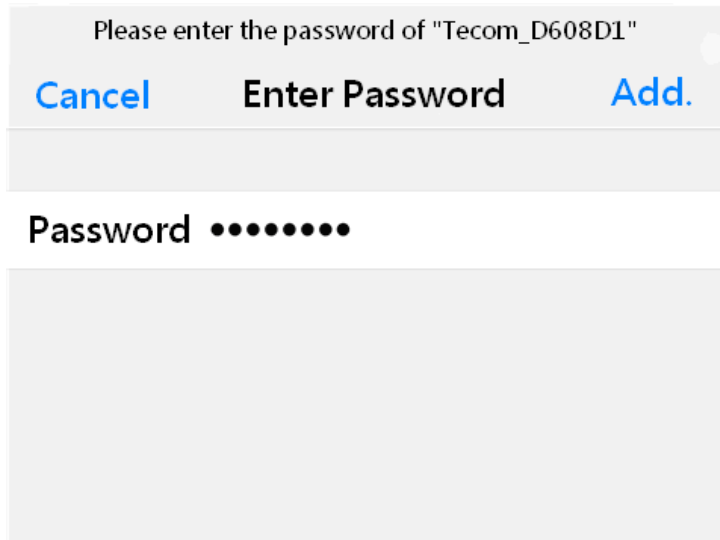

7.1.4 Station list

Users of this solution may monitor clients connected to AP.

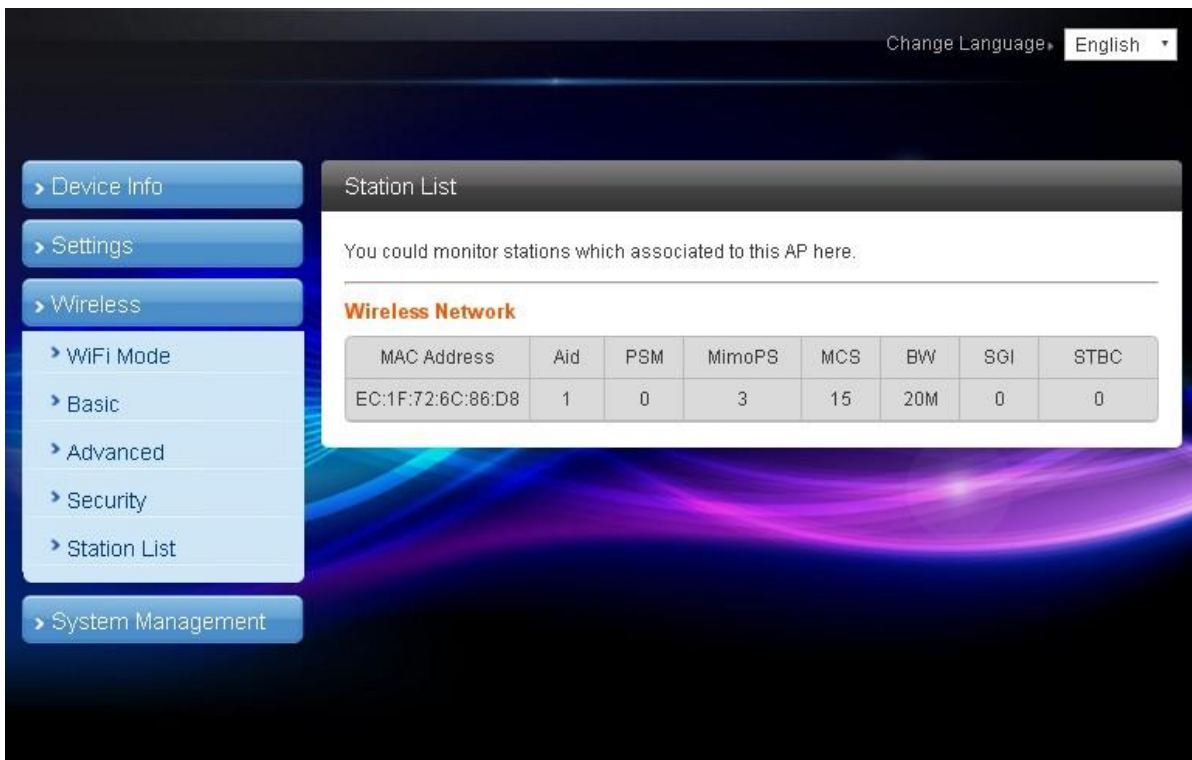

7.2 WiFi mode setting

Select STA mode and click [Apply] in the WiFi mode setting.

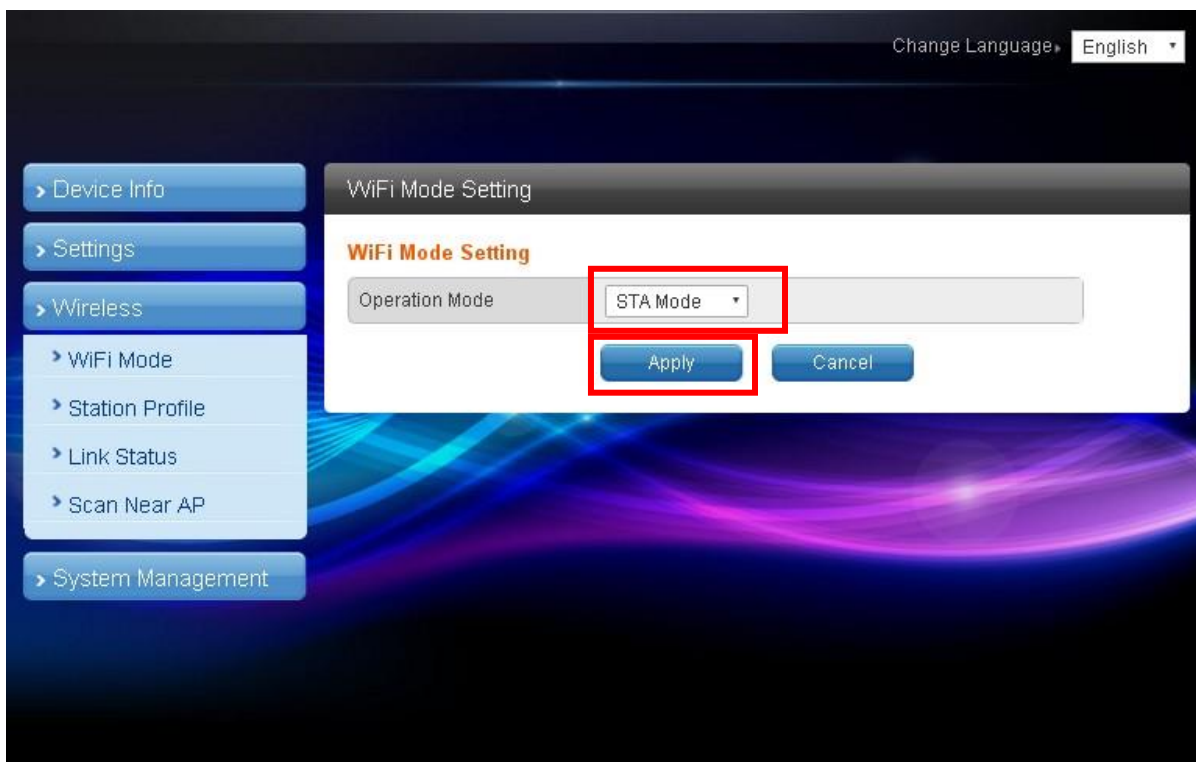

7.2.1 Station profile

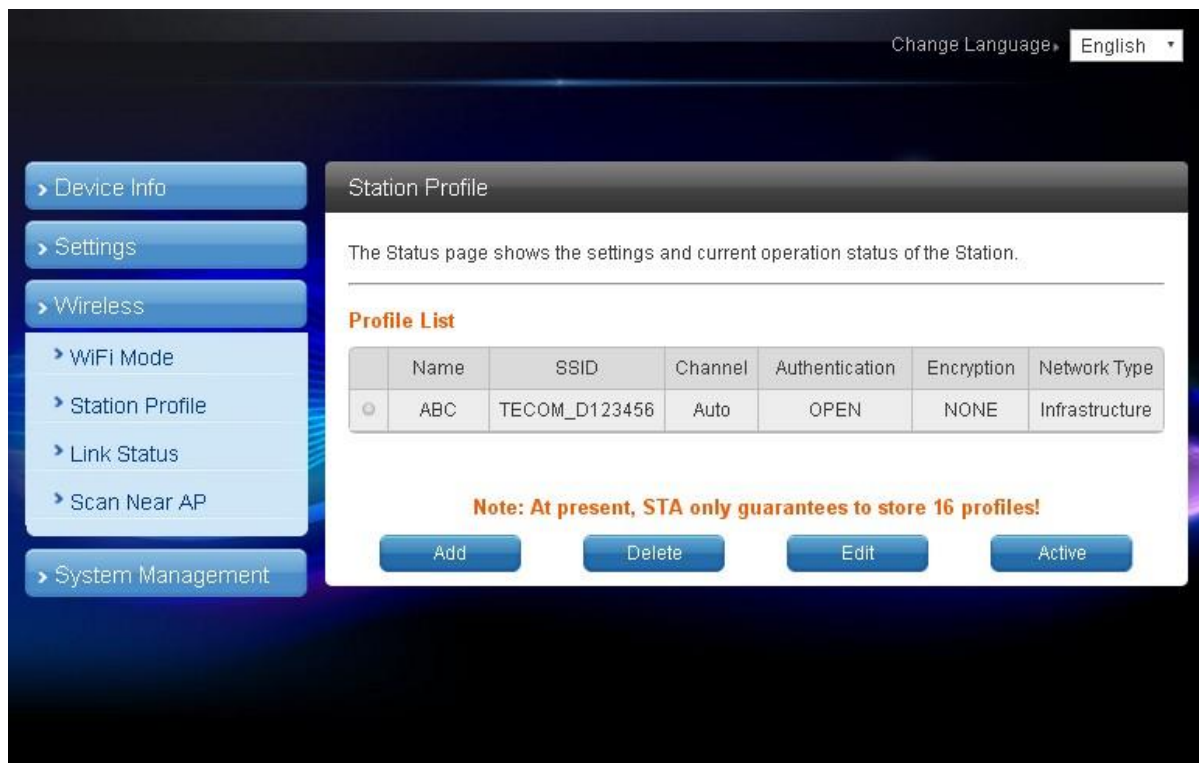

Having a gateway as an ordinary client, this page displays information of APs saved in the gateway; you may add, delete, and edit information of desired AP; select an AP and click "Open", the gateway will then auto connect to the AP; even after gateway restart connection to pre-set AP will be established automatically.

Click the "Add" or "Edit" button and the AP data edit page displays.

7.2.2 Edit station profile

Change Language English

> Device Info

> Settings

> Wireless

> WiFi Mode

> Station Profile

> Link Status

> Scan Near AP

> System Management

Edit Station Profile

System Configuration

Name	ABC
SSID	TECOM_D123456
BSSID	
Network Type	Infrastructure
Power Saving Mode	CAM (Constantly Awake Mode)
RTS Threshold	<input checked="" type="checkbox"/> Used 2347 (range 1 - 2347, default 2347)
Fragment Threshold	<input checked="" type="checkbox"/> Used 2346 (range 256 - 2346, default 2346)

Security Policy

Security Mode	OPEN
---------------	------

In most cases, users may change parameters of "Name", "SSID", "BSSID" and "Security policy" and leave default value of the others intact in the station profile edit page.

"Name": name of the profile

"SSID": name of AP

"BSSID": MAC address of AP

"Security policy": encryption mechanism of given AP

7.2.3 Station link status

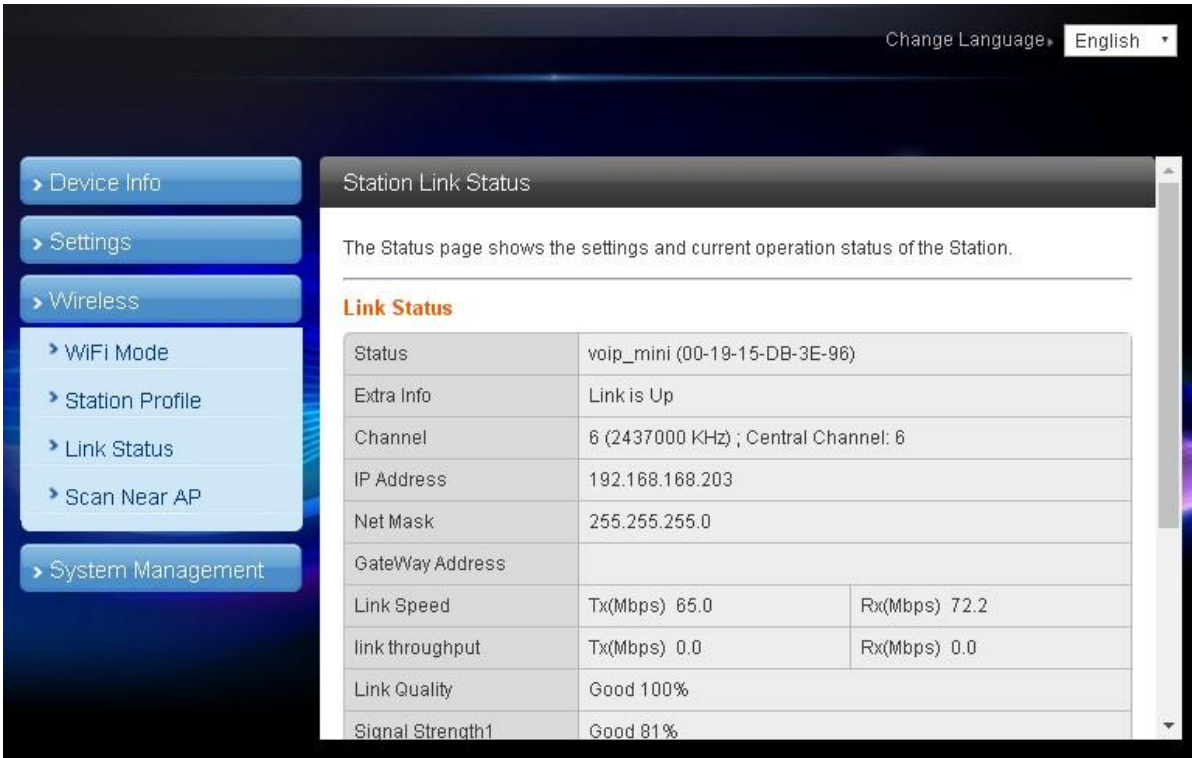

Change Language English

> Device Info

> Settings

> Wireless

> WiFi Mode

> Station Profile

> Link Status

> Scan Near AP

> System Management

Station Link Status

The Status page shows the settings and current operation status of the Station.

Link Status

Status	voip_mini (00-19-15-DB-3E-96)	
Extra Info	Link is Up	
Channel	6 (2437000 KHz) ; Central Channel: 6	
IP Address	192.168.168.203	
Net Mask	255.255.255.0	
GateWay Address		
Link Speed	Tx(Mbps) 65.0	Rx(Mbps) 72.2
link throughput	Tx(Mbps) 0.0	Rx(Mbps) 0.0
Link Quality	Good 100%	
Signal Strength1	Good 81%	

Link information after gateway connected to AP is shown here.

7.2.4 Scan near AP

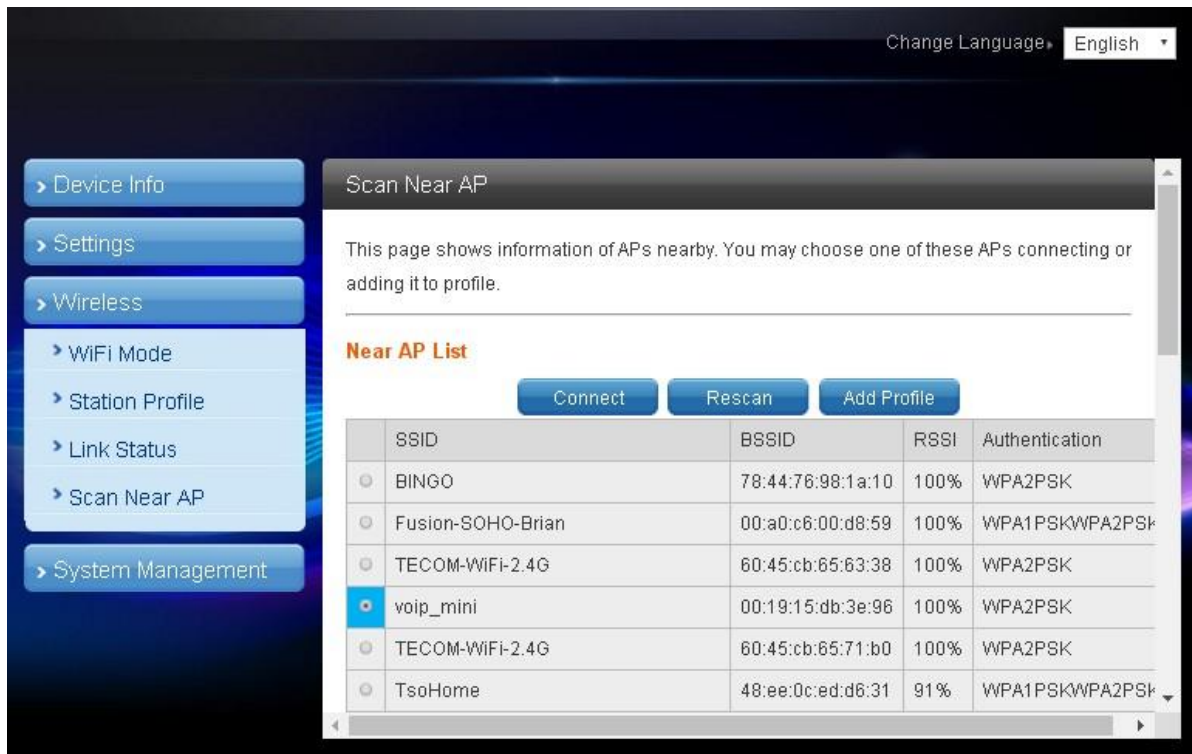

Change Language English

> Device Info

> Settings

> Wireless

> WiFi Mode

> Station Profile

> Link Status

> Scan Near AP

> System Management

Scan Near AP

This page shows information of APs nearby. You may choose one of these APs connecting or adding it to profile.

Near AP List

Connect Rescan Add Profile

	SSID	BSSID	RSSI	Authentication
<input type="radio"/>	BINGO	78:44:76:98:1a:10	100%	WPA2PSK
<input type="radio"/>	Fusion-SOHO-Brian	00:a0:c6:00:d8:59	100%	WPA1PSK/WPA2PSK
<input type="radio"/>	TECOM-WIFI-2.4G	60:45:cb:65:63:38	100%	WPA2PSK
<input checked="" type="radio"/>	voip_mini	00:19:15:db:3e:96	100%	WPA2PSK
<input type="radio"/>	TECOM-WIFI-2.4G	60:45:cb:65:71:b0	100%	WPA2PSK
<input type="radio"/>	TsoHome	48:ee:0c:ed:d6:31	91%	WPA1PSK/WPA2PSK

Scan gateway neighboring APs for information

Click "Connect" to connect the AP; data of the latter are not saved (data lost after gateway restarted).

Click "Rescan to scan" neighboring APs once again. Scanning may fail to identify all APs when there are many available nearby; rescan couple of times may be needed in case like this.

Click the "Add profile" button to save AP data in station profile file.

8. Hardware Settings

A. TT-300

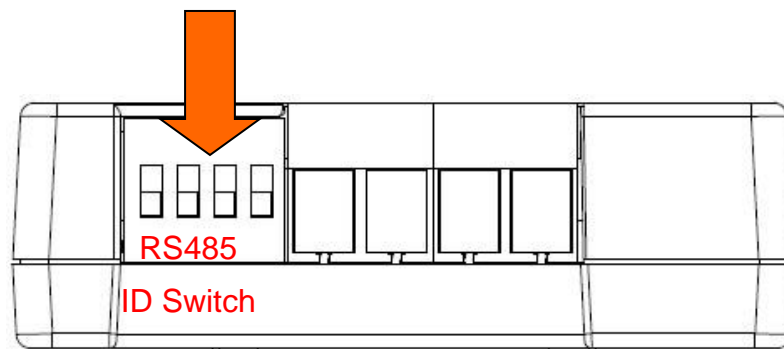

Please RS485 ID should be unique, please follow the following table to set up the RS485 ID of TT-300s:

ID	Binary Code	DIP Switch	ID	Binary Code	DIP Switch
0	0000		8	1000	
1	0001		9	1001	
2	0010		10	1010	
3	0011		11	1011	
4	0100		12	1100	
5	0101		13	1101	
6	0110		14	1110	
7	0111		15	1111	

B. AG-300 Plus Pin Assignment

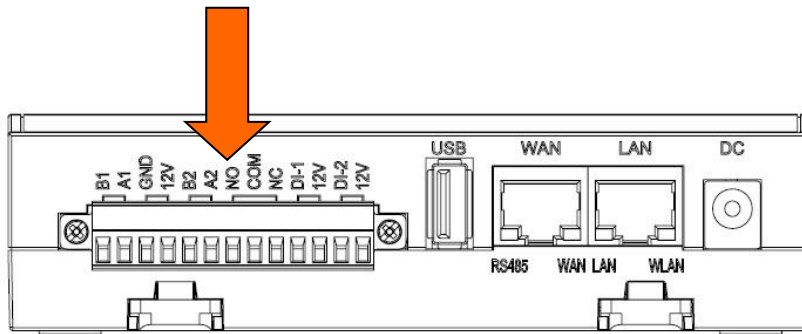

- (1) 1st RS485 pin out : Pin 1 & 2
- (2) 2nd RS485 pin out : Pin 5 & 6
- (3) DO pin out : Pin 7~9
- (4) DI pin out : Pin 10~13

Connector	Function	Description
1	B/Z	RS-485 B/Z (RS-485-)
2	A/Y	RS-485 A/Y(RS-485+)
3	GND	Ground
4	12V	+12V Output
5	B/Z	RS-485 B/Z (RS-485-)
6	A/Y	RS-485 A/Y(RS-485+)
7	NO1	Relay1 NO
8	COM1	Relay1 COM1
9	NC1	Relay1 NC
10	DTR1	Port1 Detection Alarm
11	12V	Port1 +12V Output
12	DTR2	Port2 Detection Alarm
13	12V	Port2 +12V Output

The setting instructions of Teco inverter and Tecom AG-300 Plus Gateway

This setting document is for the Teco inverter (hereinafter referred to as the inverter) and the Tecom AG-300 Plus Gateway (hereinafter referred to as the AG-300 Plus), in the hardware wiring and parameter settings for a brief description.

Wiring instructions:

RS-485 wiring between the inverter and the AG-300 Plus, the use of RS-485 for communication, can be confirmed by Figure 1 wiring instructions.

The inverter can be connected by the terminal S + / S- or RJ-45 terminals to the cloud box.

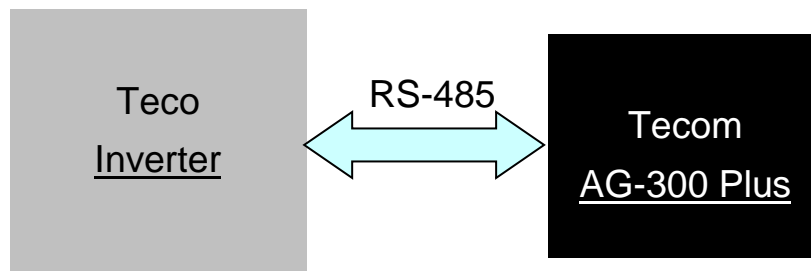

Figure 1. The description of the connection between the inverter and the AG-300 Plus

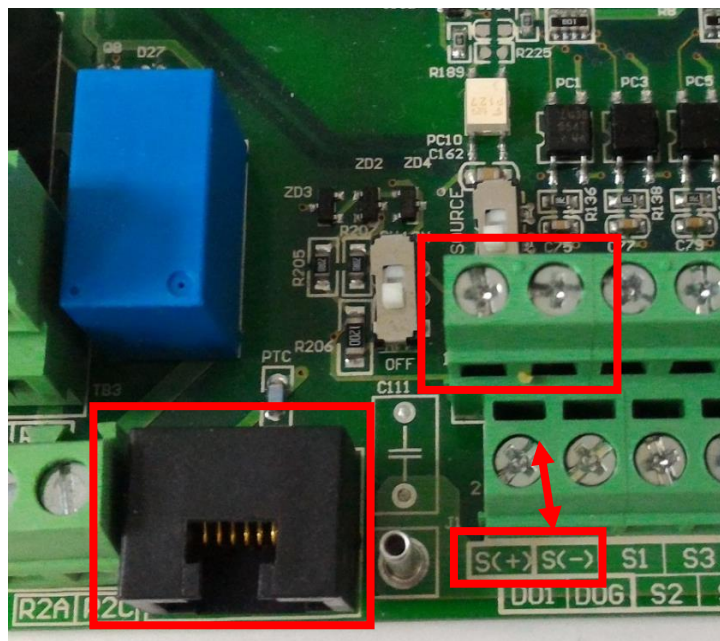
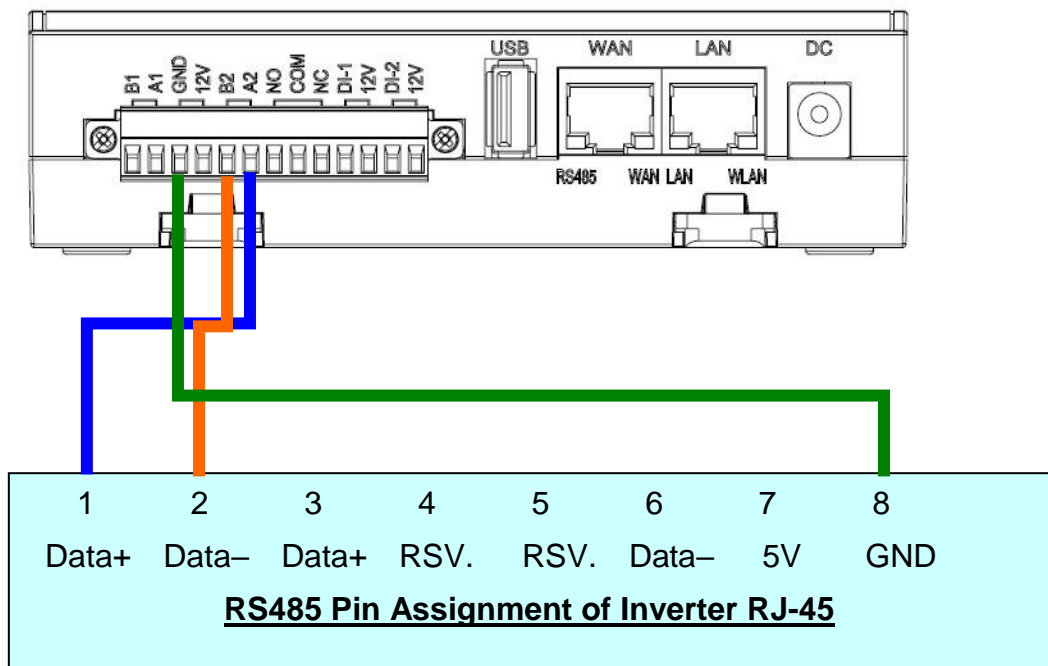

Figure 2. The hardware connection of Inverter

RS485 Pin Assignment of Inverter RJ-45 and Connect to AG-300 Plus



Parameter Setting Description:

The following is the 510 series inverter parameter setting:

00-02 (Main operate command source)	0 (Key panel)
00-05 (Main frequency command source)	3 (Communication control) for A510s/F510/E510 5 (Communication control) for L510s/E510
09-00 (Communicator station)	1 (Subject to AG300 setting)
09-01 (Communication mode selection)	0 (MODBUS)
09-02 (Baud rate setting)	3 (9600bps) for A510s/F510/E510s 1 (9600bps) for L510ss/E510
09-03 (Stop bit selection)	0 (1stop bit)
09-04 (Parity bit selection)	0 (No parity bit)
09-05 (Data bit selection)	0 (8-bit data)

The App Software Operation

Instructions of APP

Please look for PowerCloud in the APP store of IOS or in the Play store of Android to download and install the App in the mobile phone. The mobile phone must have the outbound network connection capability to use this App.

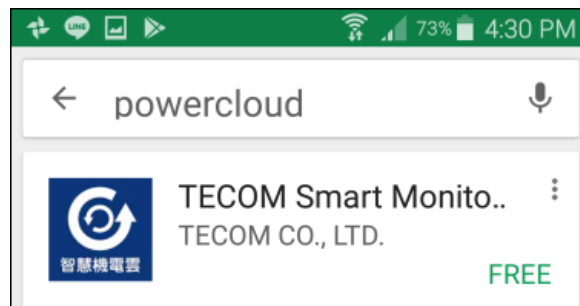

Step 1

Please start TECOM Smart Monitor System APP.

Step 2

Please click **Sign In**.

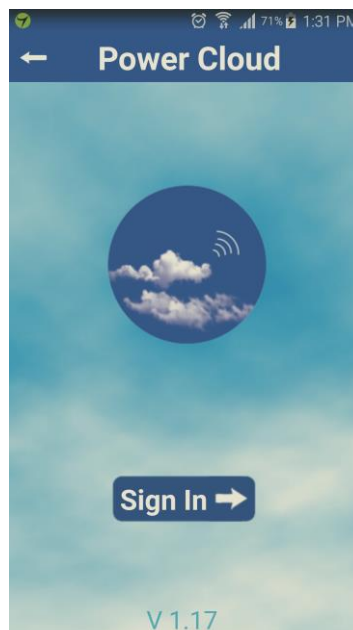

Step 3

- Account: 100 (Accounts between 100 ~ 119, total 20 sets).
- Password: Please enter personal password. (Suggested to be identical to the account)
- Server address: Please enter the IP address set in AG-300 Plus or the host ID code.
- Please click **Add** after completion of inputs.

If login failed, please confirm

1. Is the network function turned ON on mobile phone?
2. AG-300 Plus power ON?
3. AG-300 Plus setting of devices pairing
4. AG-300 Plus network function normal?

Note :

- Host ID code can be retrieved in the setting page once AG-300 Plus is connected to network.
- In the left main menu, click Device information Status overview. Host ID code can be found in System information.

Status Overview	
System Info	
Firmware Version	IP5857_MOTOR_v0.6.0SAM_r6660_2015-11-09
System Up Time	25 days 21 hours 55 minutes
Host ID	1000.11.1217.794.728

Step 4

After logged in, please click the name of the motor to enter, to retrieve the information of that motor.

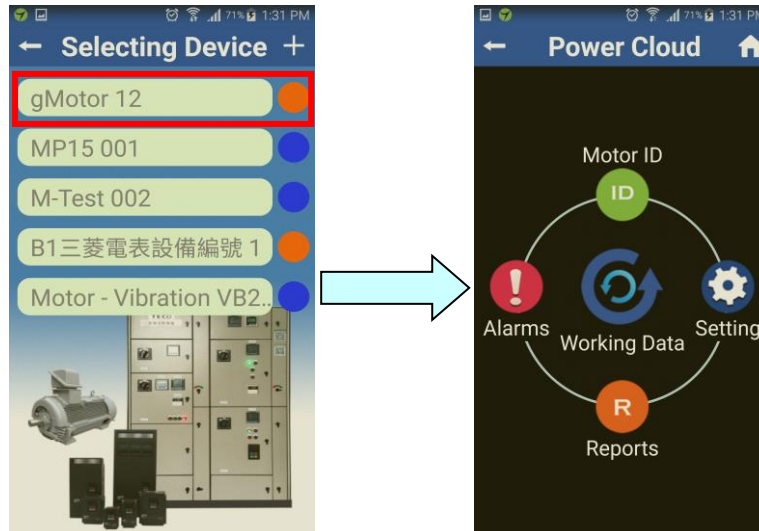
**TECOM Corp., Ltd**

No.23, R & D Rd. II,

Hsinchu Science-based Industrial Park,

HsinChu, Taiwan, 300

TEL: +886-3-5775141

FAX: +886-3-5776855

<http://www.tecom.com.tw>

Distributor



Ver:02 2018.08

This manual may be modified when necessary because of improvement of the product, modification, or change in specifications. This manual is subject to change without notice.